

GATE WELL SIZING CHART	
MINIMUM GATE WELL INSIDE DIAMETER	WATER MAIN DIAMETER
5'	6" - 8"
6'	12" - 16"
8'	> 16"

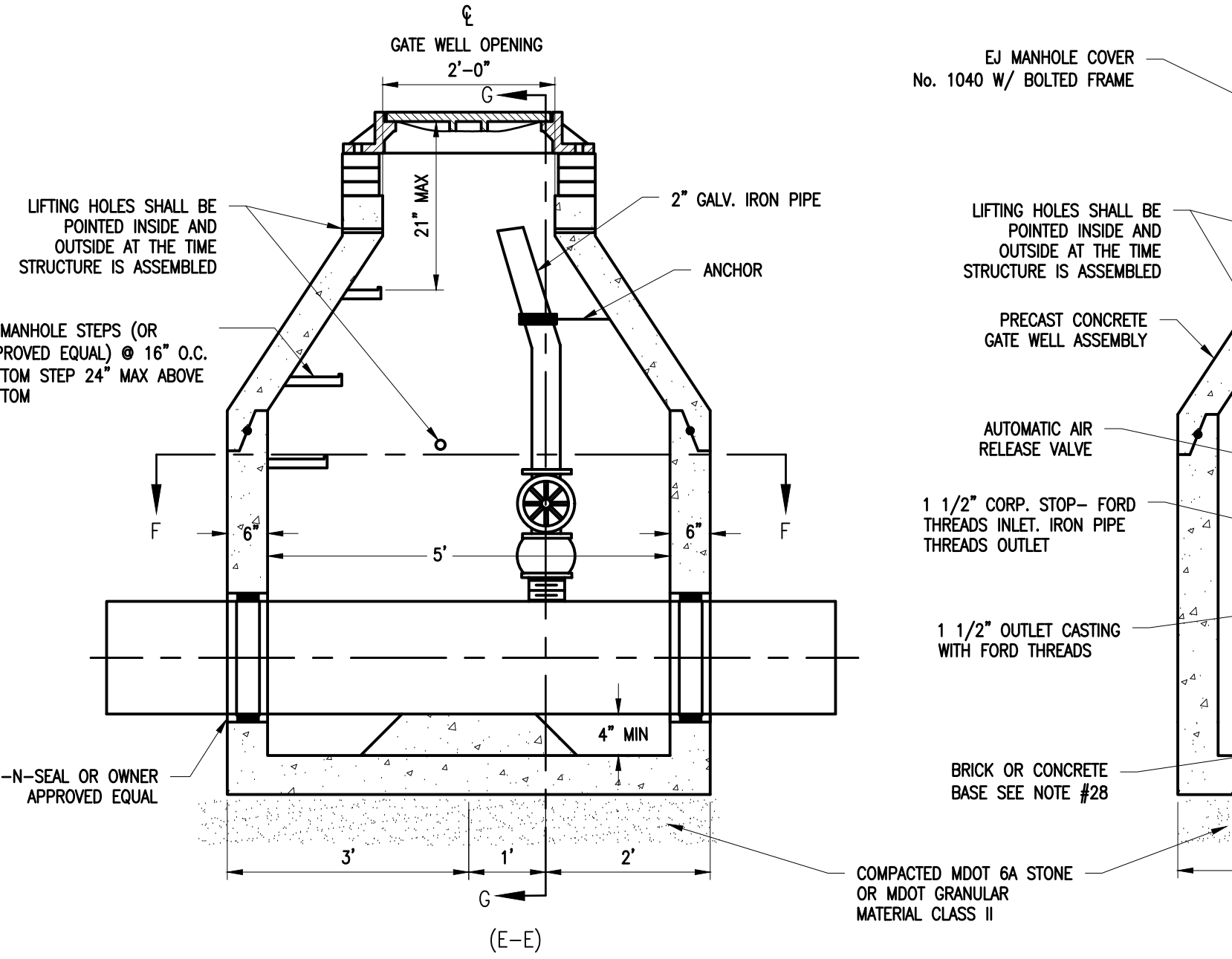

STANDARD AIR RELEASE VALVE & WELL

NOTE: ALL AIR RELEASE VALVES SHALL BE AUTOMATIC PER HARTLAND TOWNSHIP DPS REQUIREMENTS.

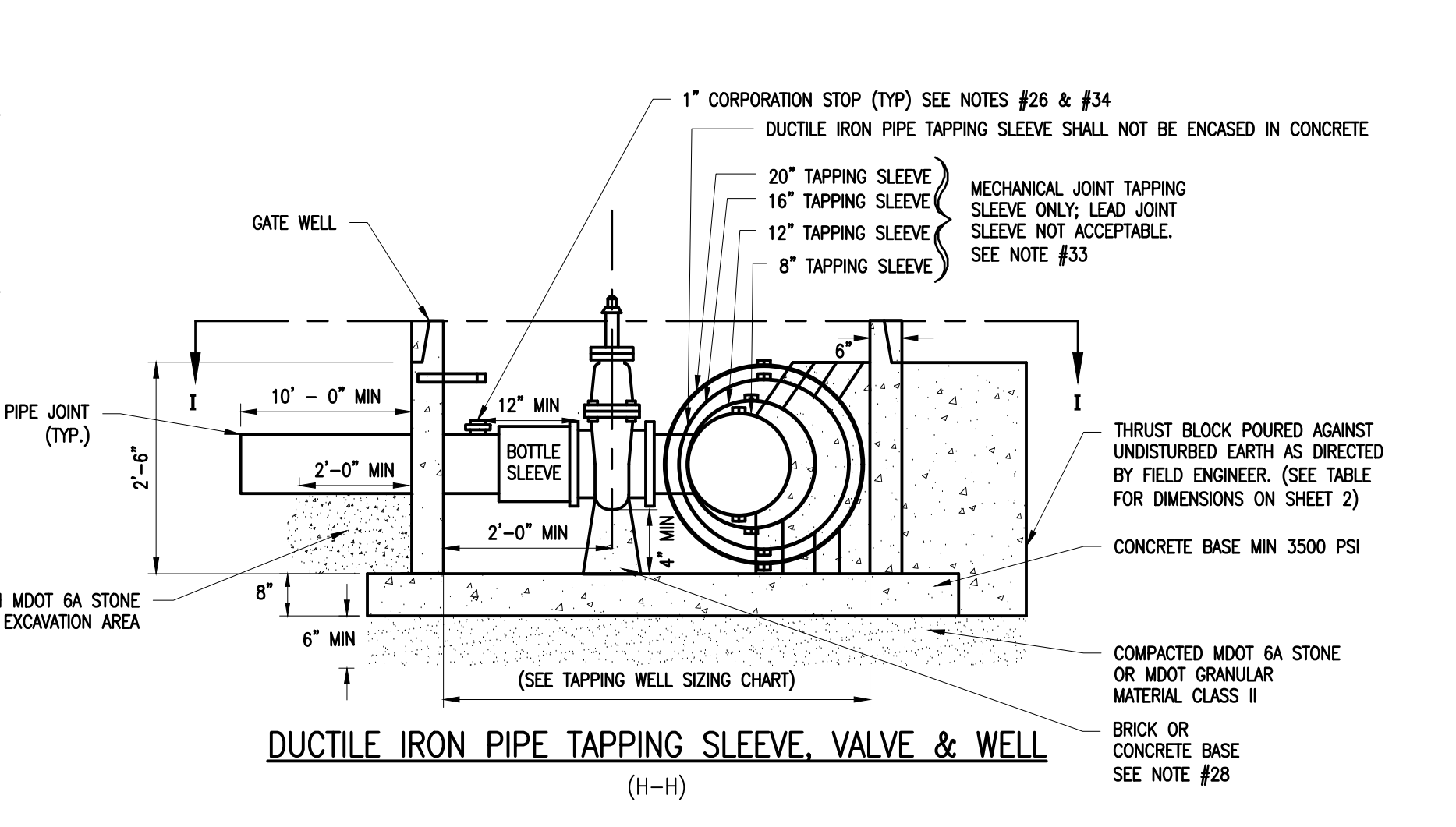
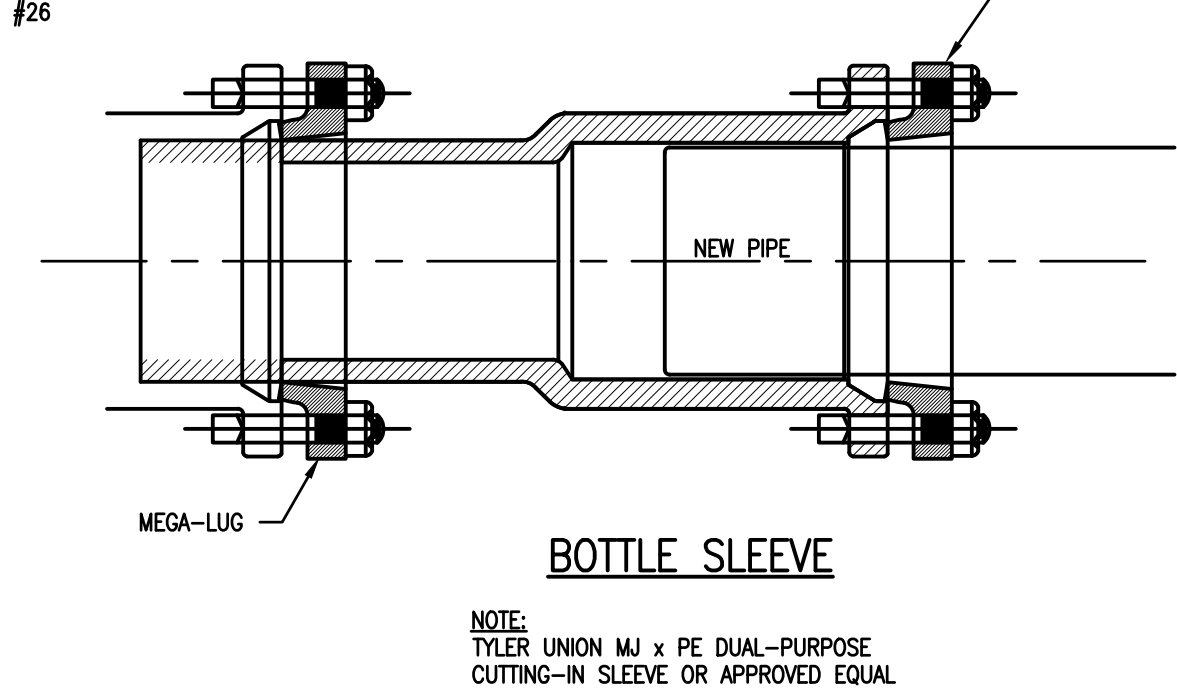
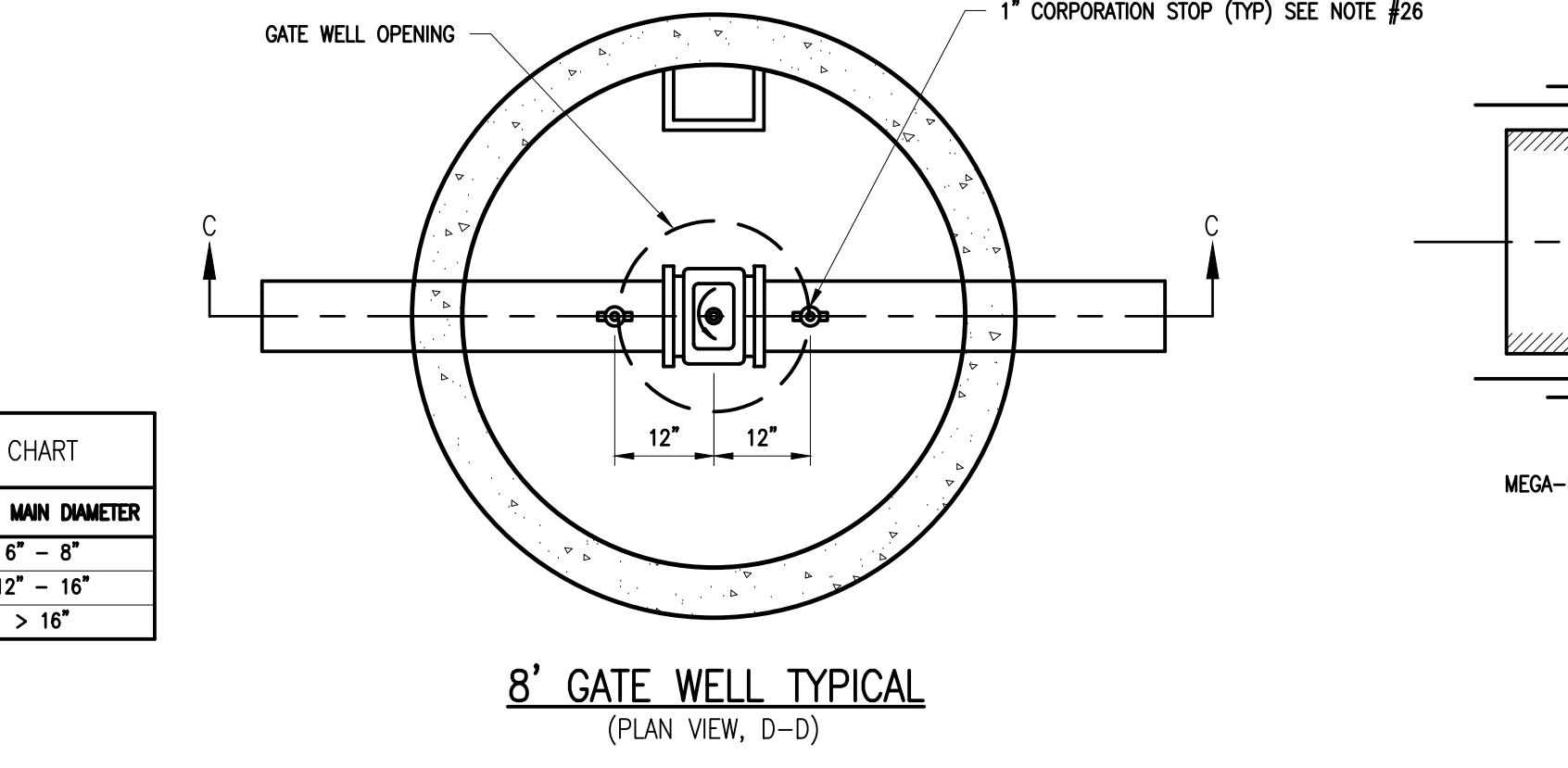
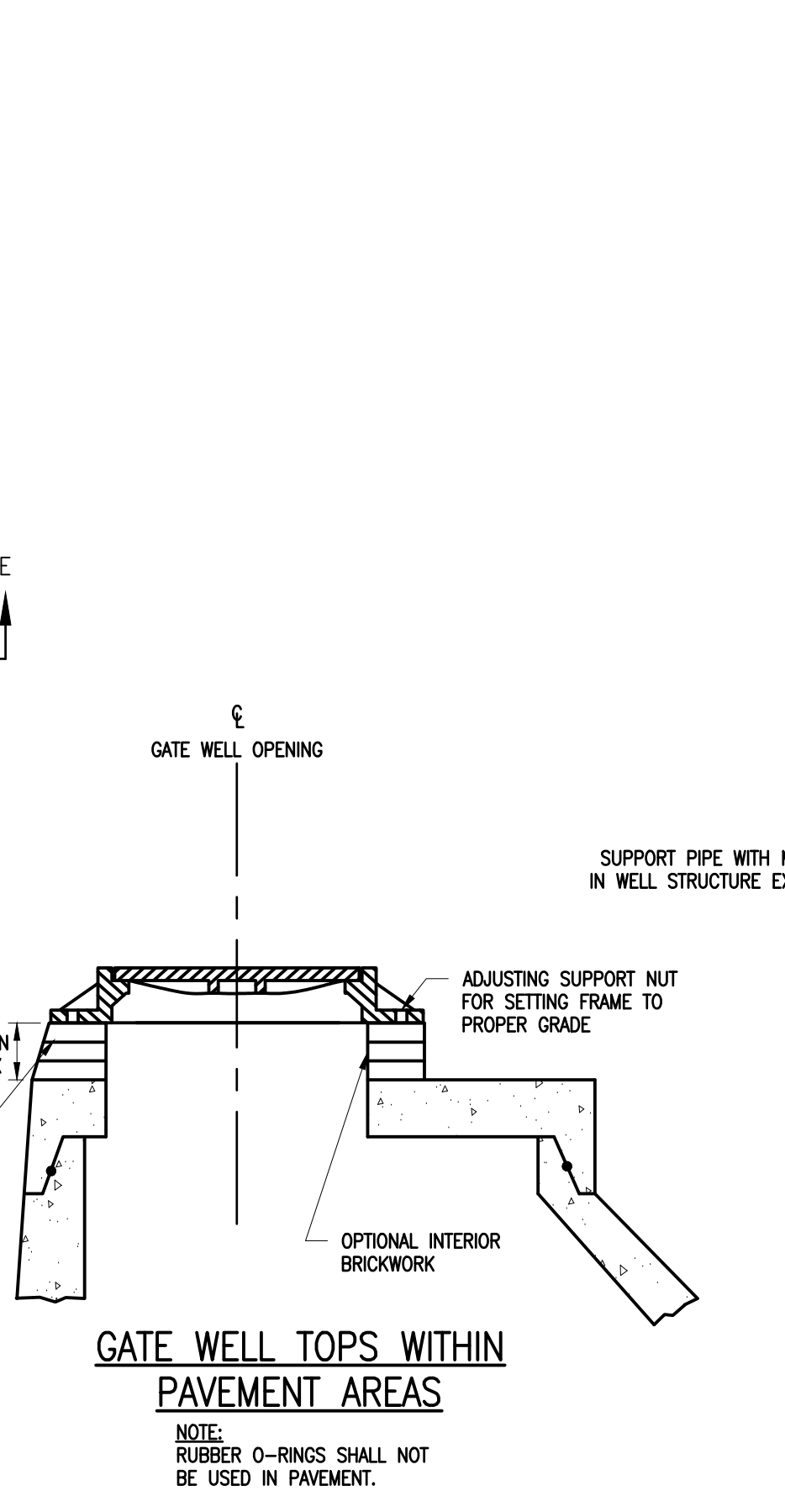
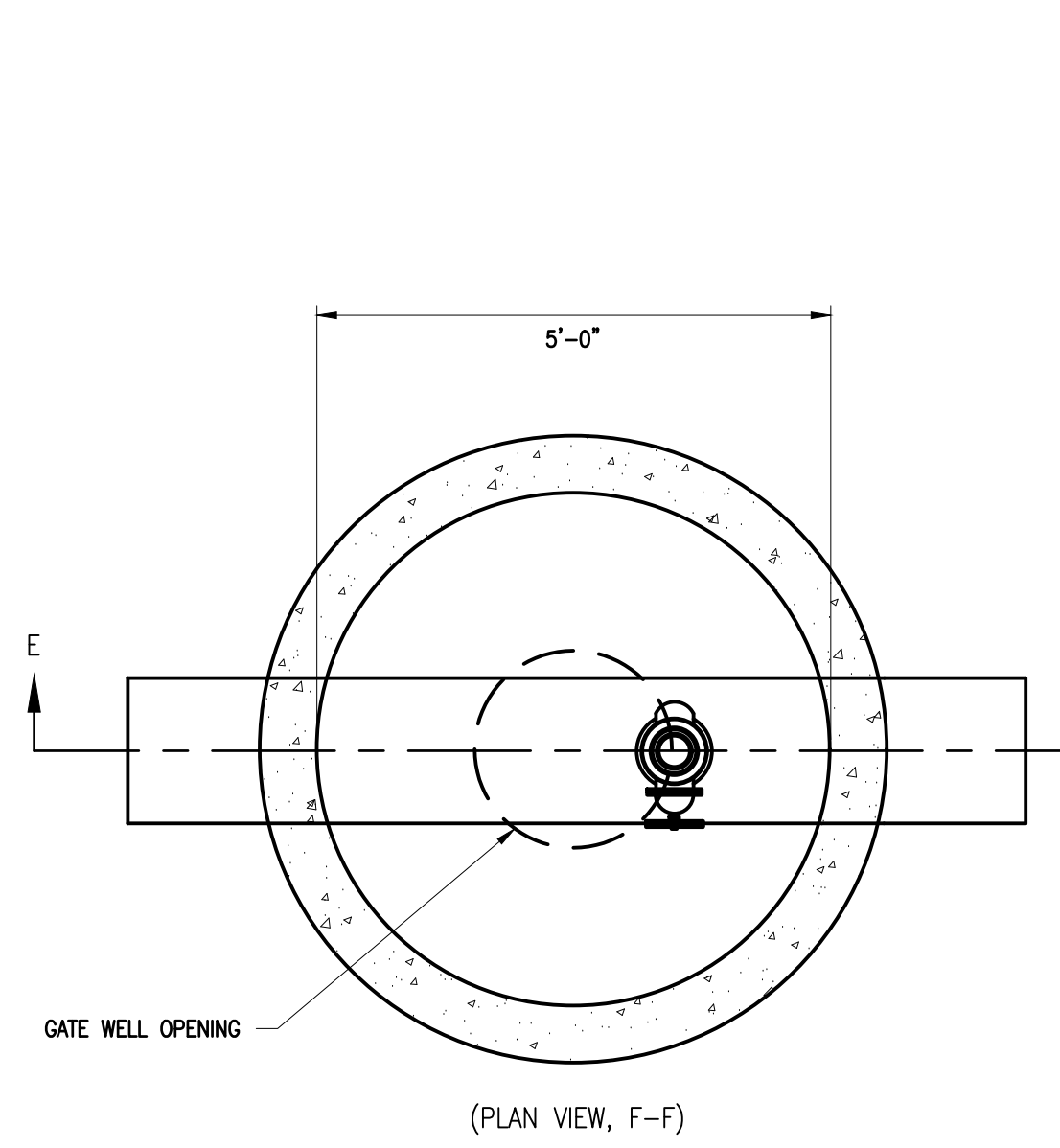

GATE WELL TOPS WITHIN PAVEMENT AREAS

NOTE: RUBBER O-RINGS SHALL NOT BE USED IN PAVEMENT.

TAPPING WELL SIZING CHART	
MINIMUM GATE WELL INSIDE DIAMETER	WATER MAIN DIAMETER
5'	8"
6'	12"
8'	16" and >

DETAILS ARE TYPICAL FOR WATER MAIN CONSTRUCTED IN CASING PIPE

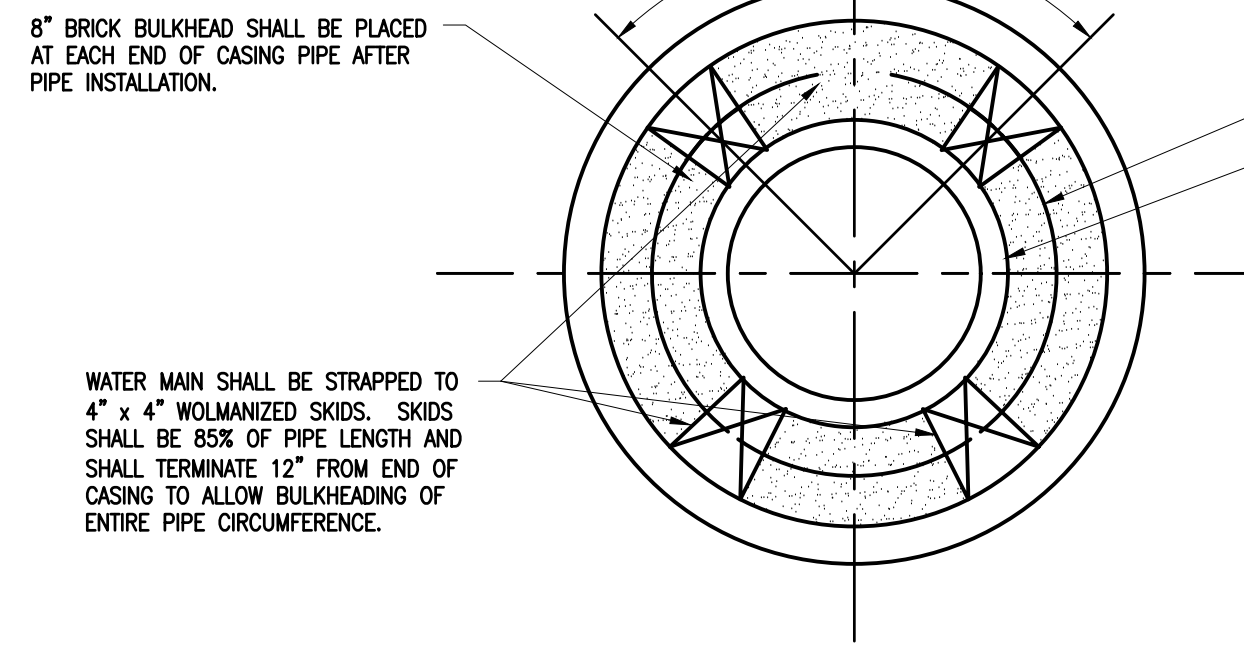

PIPE BARREL SUPPORT FOR WATER MAIN CONSTRUCTED IN CASING PIPE

DIA. OF WATER MAIN	ROAD CROSSING		RAILROAD CROSSING	
	MIN "A"	MIN "B"	MIN "B"	MIN "B"
6"	16"	.375	.375	.375
8"	16"	.375	.375	.375
12"	20"	.375	.500	.500
16"	24"	.375	.500	.500
20"	30"	.375	.500	.500
24"	36"	.375	.500	.500

A=INSIDE DIAMETER
B=WALL THICKNESS
4" MINIMUM CLEARANCE BETWEEN MAX O.D. OF THE WATER MAIN AND THE I.D. OF THE CASING PIPE FOR THE TOP 90° ARC OF THE CASING. (SEE DETAIL)

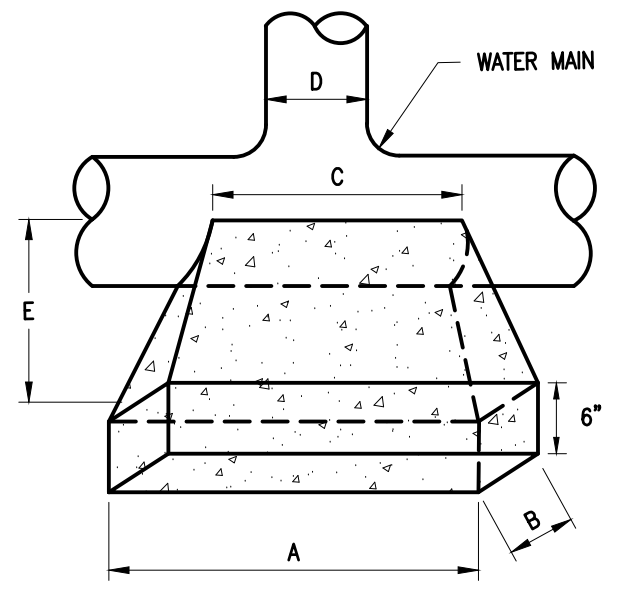

THRUST BLOCK DETAILS

FOR TEES AND TAPPING SLEEVES

D	A	B	C	E MIN
20"	6.5'	4.5'	3.5'	3'
16"	4'-8"	4'-8"	2.5'	2.75'
12"	4'	3'	2.5'	2.5'
10"	3'	2'	2'	2.25'
8"	2'-6"	2'	2'	2.25'
6"	2'	2'	2'	2.25'

NOTE:
A. 3000 PSI CONCRETE TO BE USED. THRUST BLOCK TO ABUT & REST AGAINST UNDISTURBED SOIL OR EARTH COMPACTED TO 95% MODIFIED PROCTOR.
B. THRUST BLOCKS NOT PERMITTED ON THEIR OWN, MUST BE USED IN COMBINATION WITH MEGALUG RESTRAINTS. SEE NOTE #19
C. TO BE USED AT THE DISCRETION OF THE TOWNSHIP'S CONSULTANT.

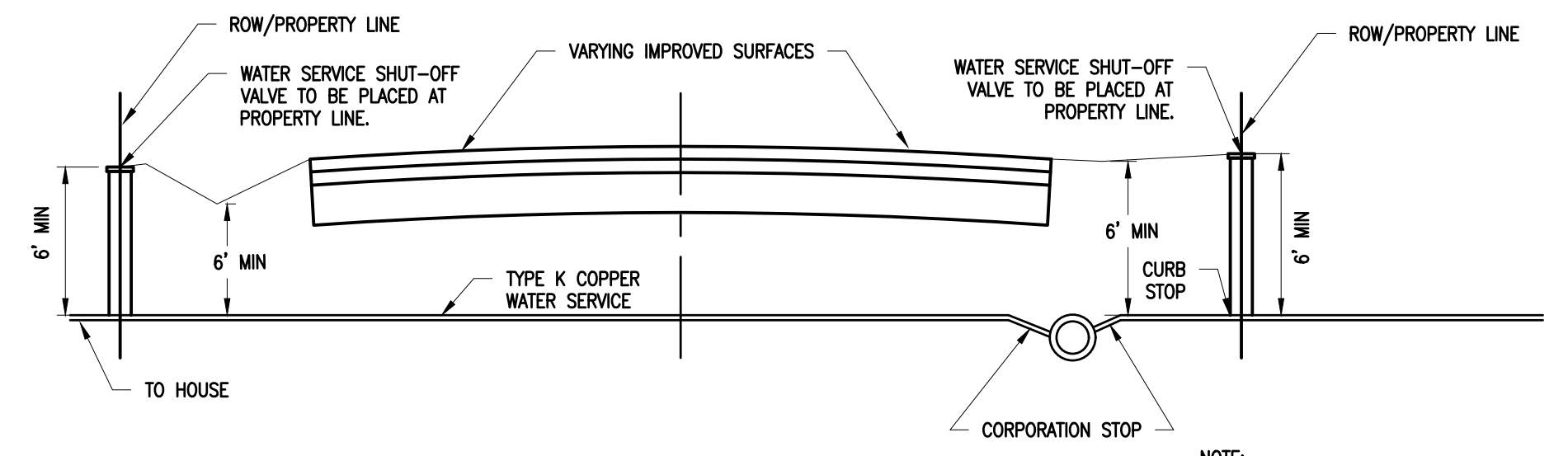

TYPICAL PUBLIC ROAD WATER SERVICE CONNECTION
(SEE NOTES #27, #29)

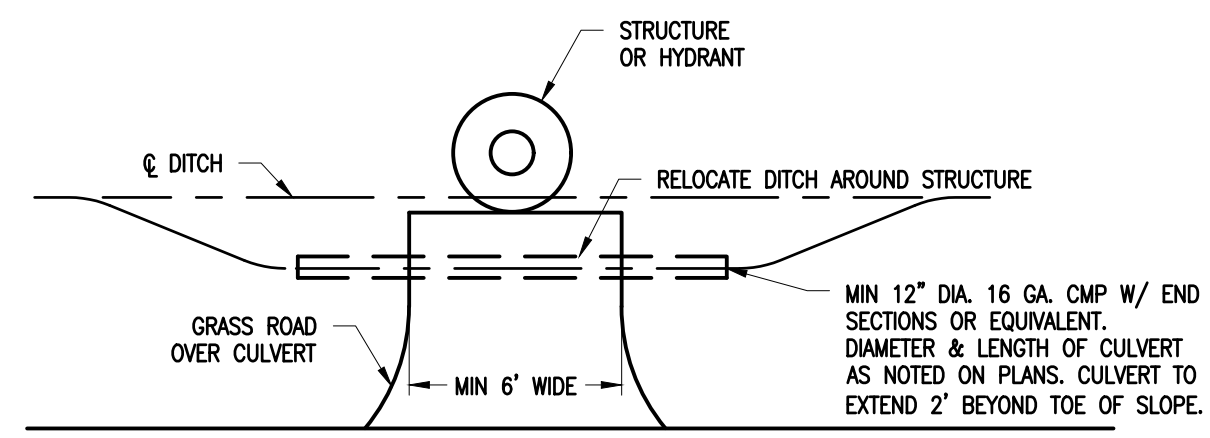

DITCH ENCLOSURE AT GATE WELL OR HYDRANT

THE CONTRACTOR SHALL SUBMIT IN WRITING THE DETAILS OF THE APPROPRIATE PIPE CASING INSTALLATION FOR THE REVIEW AND APPROVAL BY THE ENGINEER BEFORE INSTALLATION OF ANY CASING STARTS. ALTERNATE METHODS OF SUPPORTING AND MAINTAINING THE POSITION OF THE CARRIER PIPE WITH RESPECT TO THE CASING PIPE (IN LIEU OF THE USE OF TIMBERS) WILL BE CONSIDERED.

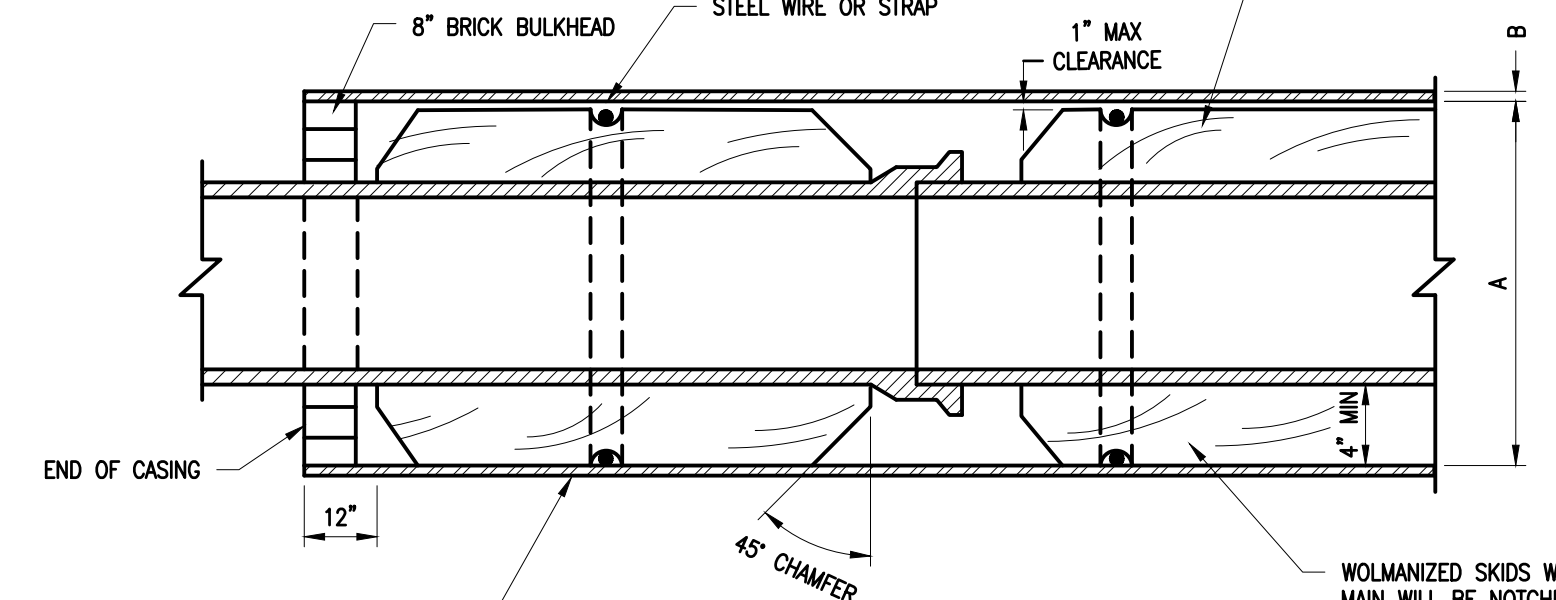

STANDARD CASING SECTION

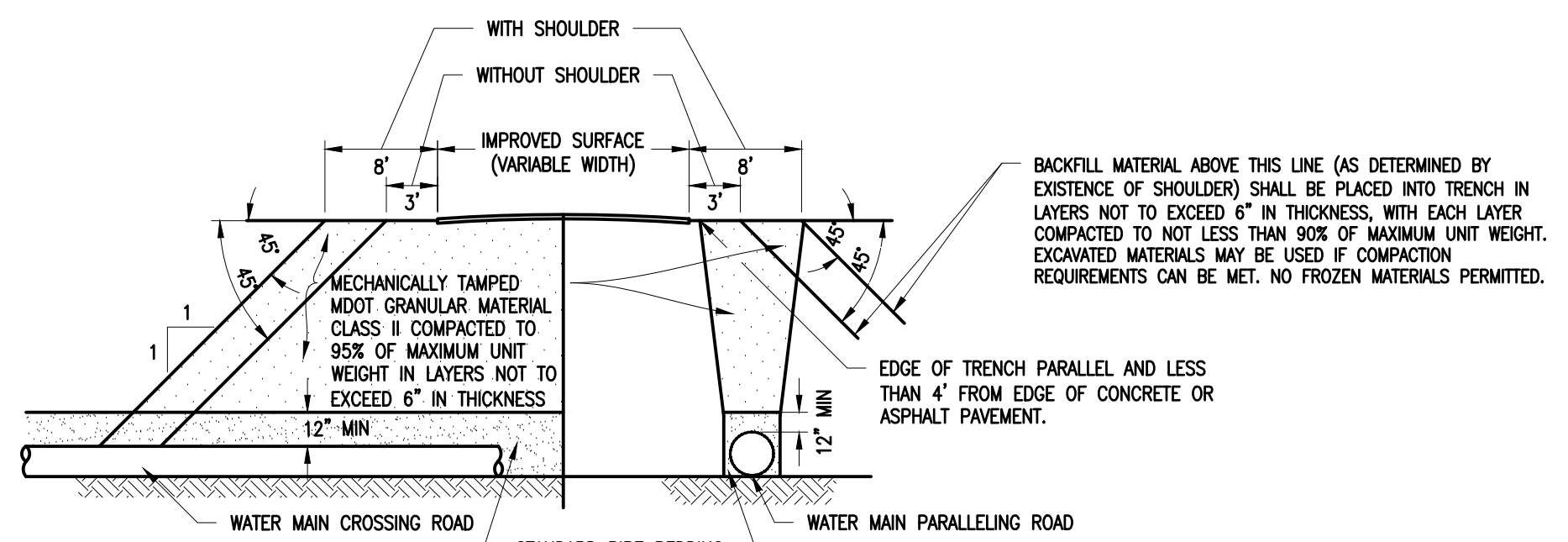

SAND OR GRAVEL BACKFILL DETAILS FOR WATER MAINS UNDER GRAVEL, CONCRETE OR ASPHALT PAVEMENTS, SIDEWALKS, DRIVEWAYS AND PARKING AREAS
(SEE NOTE #24)

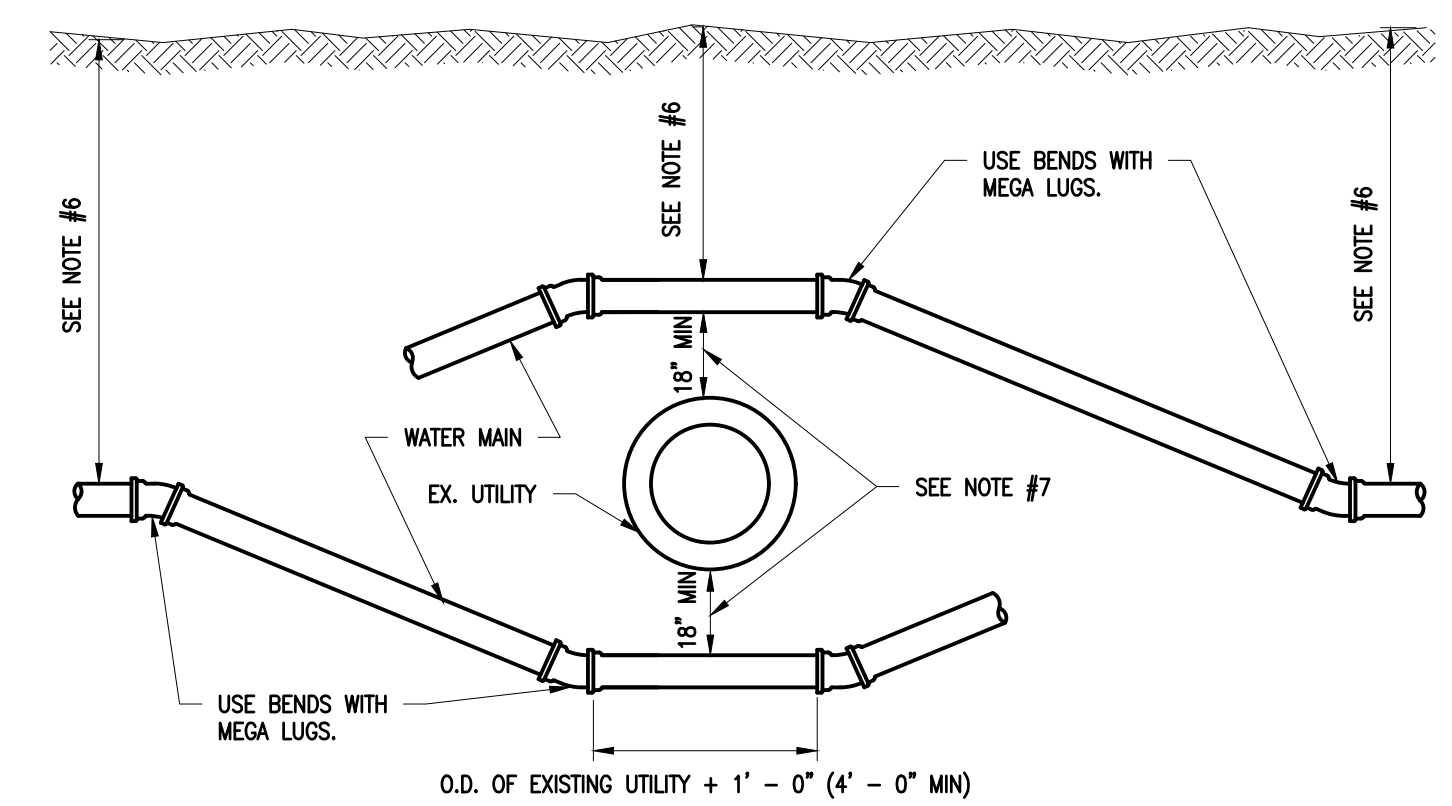

TYPICAL WATER MAIN UTILITY CROSSING
(SEE NOTE #17)

NOTE:
6A STONE BACKFILL SHALL EXTEND 9" EACH SIDE OF EXISTING PIPE, 12" ABOVE EXISTING PIPE AND SHALL BE AT A ONE ON ONE SLOPE TO THE BOTTOM OF THE TRENCH.

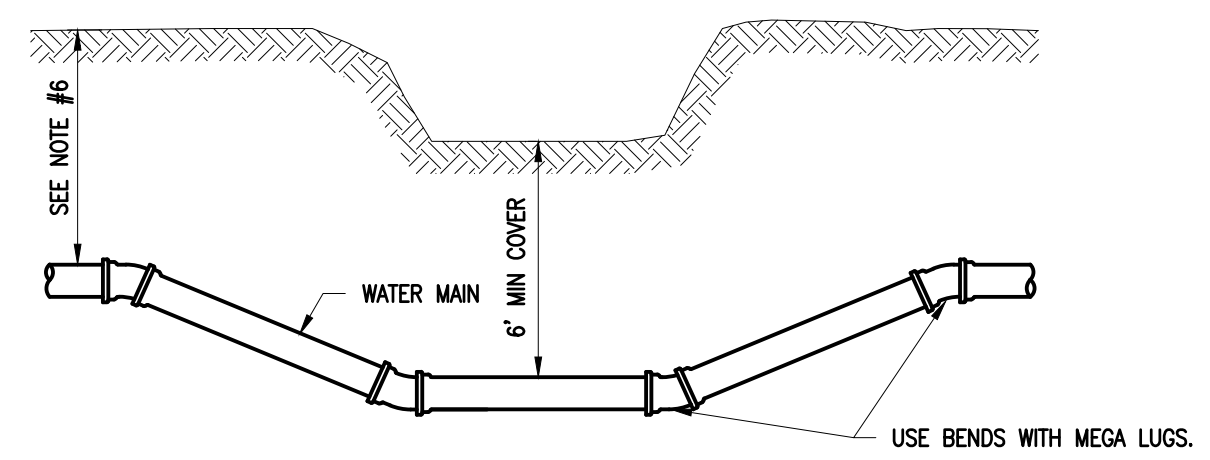

DITCH, STREAM OR WETLAND CROSSING

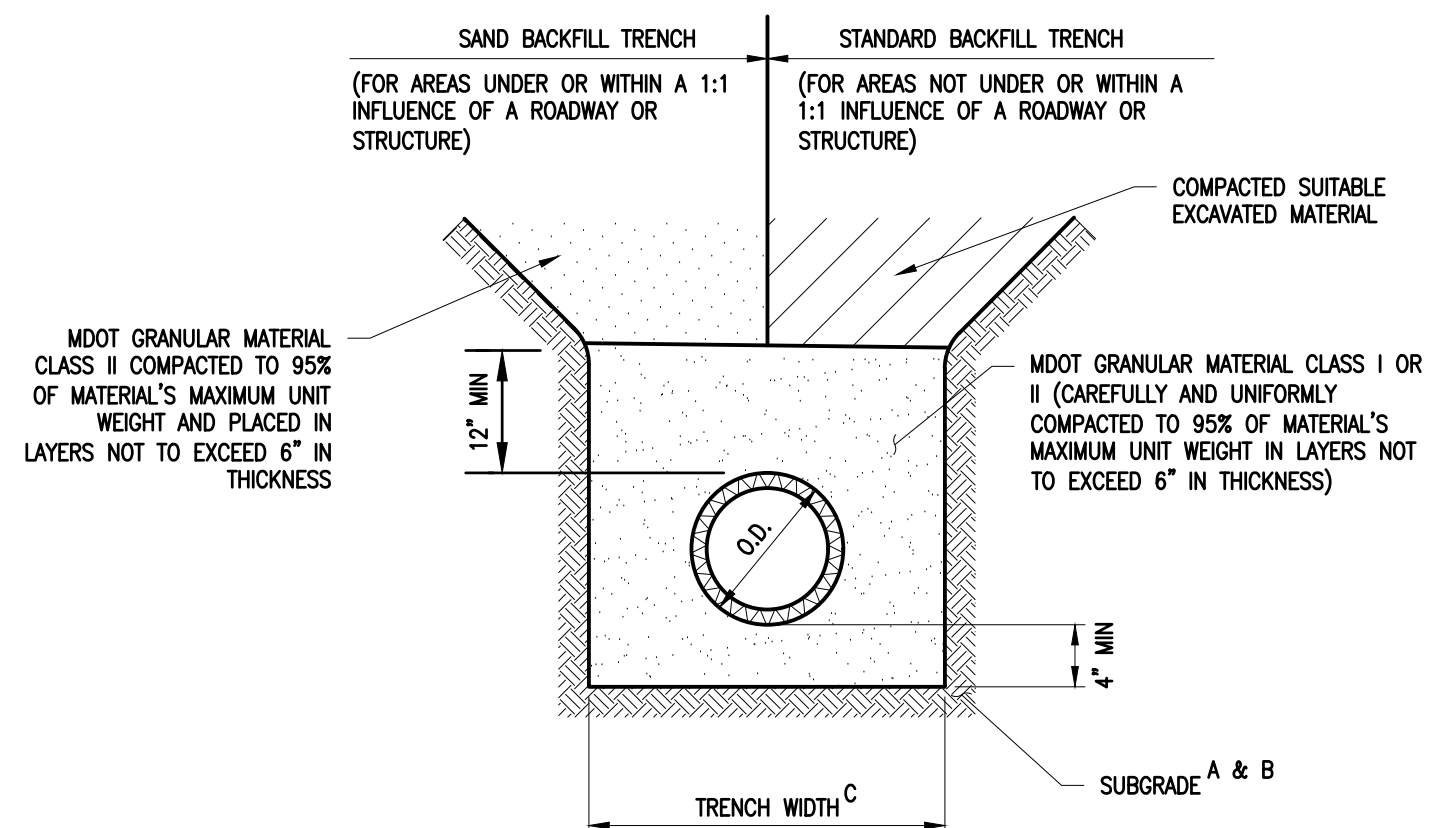

BEDDING AND TRENCH BACKFILL DETAIL
(SEE NOTE #24)

NOTES:
A. IF THE EXISTING SUBGRADE SOILS MEET THE REQUIREMENTS FOR MDOT GRANULAR MATERIAL CLASS II (MINIMUM 4" THICK), THEN THE WATER MAIN MAY BE LAID DIRECTLY ON THE COMPACTED NATIVE SUBGRADE SOILS.
B. FIELD CONDITIONS MAY REQUIRE UP TO 18" OF MDOT 6A STONE IN ORDER TO SECURE A FIRM TRENCH BOTTOM. ADDITIONAL DEPTH OF TRENCH UNDERCUT SHALL BE DIRECTED BY A GEOTECHNICAL ENGINEER AND SHALL BE REFILLED WITH 1" x 3" STONE.
C.

MAXIMUM TRENCH WIDTHS	
I.D. PIPE SIZE	TRENCH WIDTH
UP TO 12"	30"
15" TO 36"	O.D. + 12"
42" OR LARGER	O.D. + 24"

DATE: _____
REVISIONS: _____
SCALE: V. N.T.S.
COUNTY: LIVINGSTON COUNTY
TOWNSHIP: HARTLAND TOWNSHIP
RANGE: _____
DATE: _____

WATER MAIN CONSTRUCTION NOTES

GENERAL NOTES:

- All construction procedures and materials used on all water main projects shall conform to AWWA and Hartland Township current Standards and Specifications.
 - No water main is to be installed without Township inspection.
 - Three (3) working days prior to construction, the Contractor shall telephone MISS DIG (811 or 1-800-482-7171) for underground facilities locations and shall also notify representatives of other utilities located in the vicinity of the work.
 - All pipe and all pipe fittings shall be made in the U.S.A.
 - Unless otherwise specified on plans, top of all water mains shall be six (6) feet below existing or proposed gravel, concrete or asphalt pavements, sidewalks, driveways and parking areas.
 - Whenever a water main is installed under existing utility line, GA stone shall be used to properly support or distribute any concentrated loads to avoid any settlement and all possible failure of the lower main. A vertical separation of at least 18 inches between the utility and the water main shall be provided (measured barrel to barrel).
 - All required cross connection devices shall be installed as required by the local plumbing code and in accordance with the standards of the Michigan Department of Environmental Quality Water Resources Division and the Michigan Department of Public Health.
 - Connection to an existing water main shall be made only after pressure and bacteriological tests have been successfully completed. The Township consultant must be present for the tests and review the results. Testing and disinfection procedures shall meet the requirements of ANSI/AWWA-C600/C651. The water main shall pass a test of 150 psi for a two (2) hour period. Water loss shall not exceed a rate of 11.65 U.S. gallons per inch diameter per mile of water main in twenty-four (24) hours.
 - a. All watermain 8" or larger shall be cleaned with a poly pig.
 - The Township consultant must witness the connection of the water main to the existing water main. After the Township consultant approval letter has been issued, residential and commercial taps will be allowed. All water service connections two (2) inches and smaller shall be made by Hartland Township DPS.
 - Contractor supplied gauges are required for testing. The minimum size shall be 3.5" diameter graduated in one (1) or two (2) pound increments from 1 to 160 psi (minimum range).
 - When temporary water main jumpers are used during water main construction, a testable RPZ backflow preventer with current test report shall be placed on the jumper hose that is connected to the new water main.
 - The materials specified below may be substituted with an approved equal as determined by the Township. It is at the sole discretion of the Township to determine if a material is acceptable and can be utilized. Written authorization must be obtained prior to ordering or installing the approved equal.
- WATER MAIN NOTES:**
- All water main shall be ductile iron or concrete. HDPE water main may be permitted upon Township approval. Water main shall be per the following specifications:
 - Ductile iron pipe shall be ANSI/AWWA C151/A21.51 cement lined with bituminous seal coat Class 54 for sizes 3" through 16" and Class 55 for 20" through 24" pipe. Ductile iron pipe shall be designed for a minimum working pressure of 150 psi.
 - Pre-stressed Concrete Cylinder pipe (P.C.C.P.) shall be AWWA C-301 specification for sizes larger than 24".
 - High Density Polyethylene (HDPE) SDR 9 or 11 pipe shall meet the requirements of AWWA C905 (SDR 11) with blue shell or blue stripes.
 - Water services up to 2" shall be either Type K soft copper or HDPE DR9 with tracing wire meeting the requirements of ANSI/AWWA C909 for a pressure class of 200 psi. If HDPE is used, a tracing wire shall be run from the meter setup to the curb box (See item #9 for tracing wire requirements). All water services greater than 2" shall follow the standards listed in item #15.
 - The maximum allowable deflection at joints for ductile iron water main shall be per manufacturers standards (i.e. 4" - 36" water main - 5" per 20').
 - Poly-wrap may be required by the Township and shall be placed around the water main per manufacturers specifications.
 - MEGALUG shall be placed at all valves, bends, tees, plugs, hydrants and mechanical fittings. Surrounding joints shall be restrained using U.S. Pipe Field Lok gaskets or approved equal and shall be per the manufacturer's joint restraining schedule and the latest edition of DIPRA's Thrust Restraint Design for Ductile Iron Pipe.
 - Water main joints shall be Tylon, Fastite, Mechanical, or approved equal in accordance with ANSI/AWWA C111/A21.1.
 - Restrained joints are required in lieu of thrust blocks. Restrained joints for pipe sizes up to 16" shall be Fast Grip Gaskets, Mega Lug or approved equal. Restrained joints for pipe sizes over 16" shall be American Ductile Iron Flex-Ring Joint Pipe or approved equal boltless system.
 - Thrust restraint design shall be per the Ductile Iron Pipe Research Association's Manual of Thrust Restraint Design for Ductile Iron Pipe, current edition.
 - All bolts on all flanged and mechanical joint fittings shall be domestic origin high strength, low alloy COR-BLUE steel bolts or approved equal. These bolts shall meet the current provisions of American National Standard ANSI/AWWA C111/A21.11 for rubber gasket joints for ductile iron pressure pipes and fittings. Bolt manufacturer's certificate of compliance must accompany each shipment.
 - Backfill shall be compacted above pipe as indicated on construction drawings. Trench backfill shall be a suitable material and shall be free of any organic materials and rocks larger than 3" in size. Under road surfaces, pavement, sidewalks, curbs, driveways and areas where trench is within a 1:1 influence of the

pavement, sand backfill shall be used which shall consist of MDT granular material Class 1 and shall be compacted in layers not to exceed six (6) inches in thickness to a density of 95% as determined by ASTM D 1557. Where water main is to be placed on fill material, all fill material below the pipe must also be compacted to 95% maximum unit density. All backfill placed within a 1:1 influence of structures shall be approved sand, placed in six (6) inch layers and compacted. Trenches that are to be left open overnight shall be enclosed with suitable fencing and lighted barricades.

VALVE & SERVICE NOTES:

- All Gate Valves less than 16" shall be EJ ductile iron body, fully bronze-mounted, resilient-wedge, non-rising stem (ANSI/AWWA C508), opening counterclockwise.
 - Corporation Stops shall be 1-inch Ford #B44, or approved equal. Corporation stops shall be securely capped after testing. Must use lead free corps.
 - All service lead corporation stops installed outside of gate wells 1" or less may be direct tapped to main. For corporation stops larger than 1" use bronze double strap tapping saddle.
 - Gate valves and fittings shall be supported by formed concrete or mortared brick bearing on the floor (minimum four (4) inches of clearance between floor and bottom of gate valve).
 - All gate valves 6" or larger shall be placed in a well with the exception of a hydrant shut off valve. A valve shall be placed in a box for water main smaller than 6". A stop box and rod is required for services up to 2" and a hydrant valve box is required for services less than 6". If the box falls within a paved area, a hydrant valve box is required for all service sizes.
 - Butterfly valves shall be used for valves 16" and larger in diameter and shall be Deszurik AWWA style, or approved equal, manufactured in accordance with ANSI/AWWA C504 and conforming to NSF Standard 61.
 - All precast concrete gate well sections shall be manufactured to conform with ASTM C478, except wall thickness shall be as shown on these details. Precast concrete gate well sections shall be modified tongue and groove with premium rubber gasket-type joints manufactured to conform with ASTM C443.
 - All gate well covers shall be EJ #1040A with bolted frame and with lettering per detail on this sheet. All cover bolts shall be stainless steel.
 - Tapping sleeves shall be manufactured by JCM Industries, Romac Industries, Mueller, EJ, Smith-Stair or approved equal and shall be mechanical joint with DNS Mechanical Joint Tapping Gate Valve. Lead joint sleeves shall not be used. Like size tapping sleeves can only be used when the existing main is ductile iron and equal to/less than 12-inch in diameter. For like size connections greater than 12-inch, a cut-in-tee is required. All tapping sleeves must be mechanical tapping sleeves.
 - No tapping of any water main fitting will be permitted.
 - No water main fittings or water service fittings shall contain lead.
- HYDRANT NOTES:**
- All hydrants shall be 6" bury EJ #5BR-250-Traffic Model and shall conform to ANSI/AWWA C502, and shall have a minimum 5 1/4" valve opening that closes with the water pressure. Hydrants shall be traffic style with breakable flange and coupling.
 - Hydrants shall have a swivel flange to allow bonnet to be turned 360 degrees without removing the bonnet, and barrel flanges shall be integrally cast with the barrel. Inlet shoe shall have a bronze valve seat, which can be removed without digging.
 - Inlet connection shall be 6" mechanical joint, conforming to AWWA C111 and ASA-421.11. Stem threads shall be sealed with double "O" rings and shall be permanently lubricated with all weather grease.
 - Hose connections: One (1) 4 1/2" pumper nozzle and two (2) 2 1/2" hose nozzles, with National Standard Thread (NST) threads. Final orientation of the hydrant steamer connection to be determined by Township consultant or Fire Department.
 - Operating Nut: (1) 1 1/8" P-F pentagon, open left.
 - Hydrants shall be factory painted by spray application red above the ground and black below, with a finish coat of Glomortex 501 enamel, color 314 Vermillion, or approved equal.
 - Prior to acceptance, hydrants shall be charged, tested and any leaks are to be repaired. Hydrants and valve boxes shall be plumbed and set to finished grade. Valve boxes shall be in line with the valve.

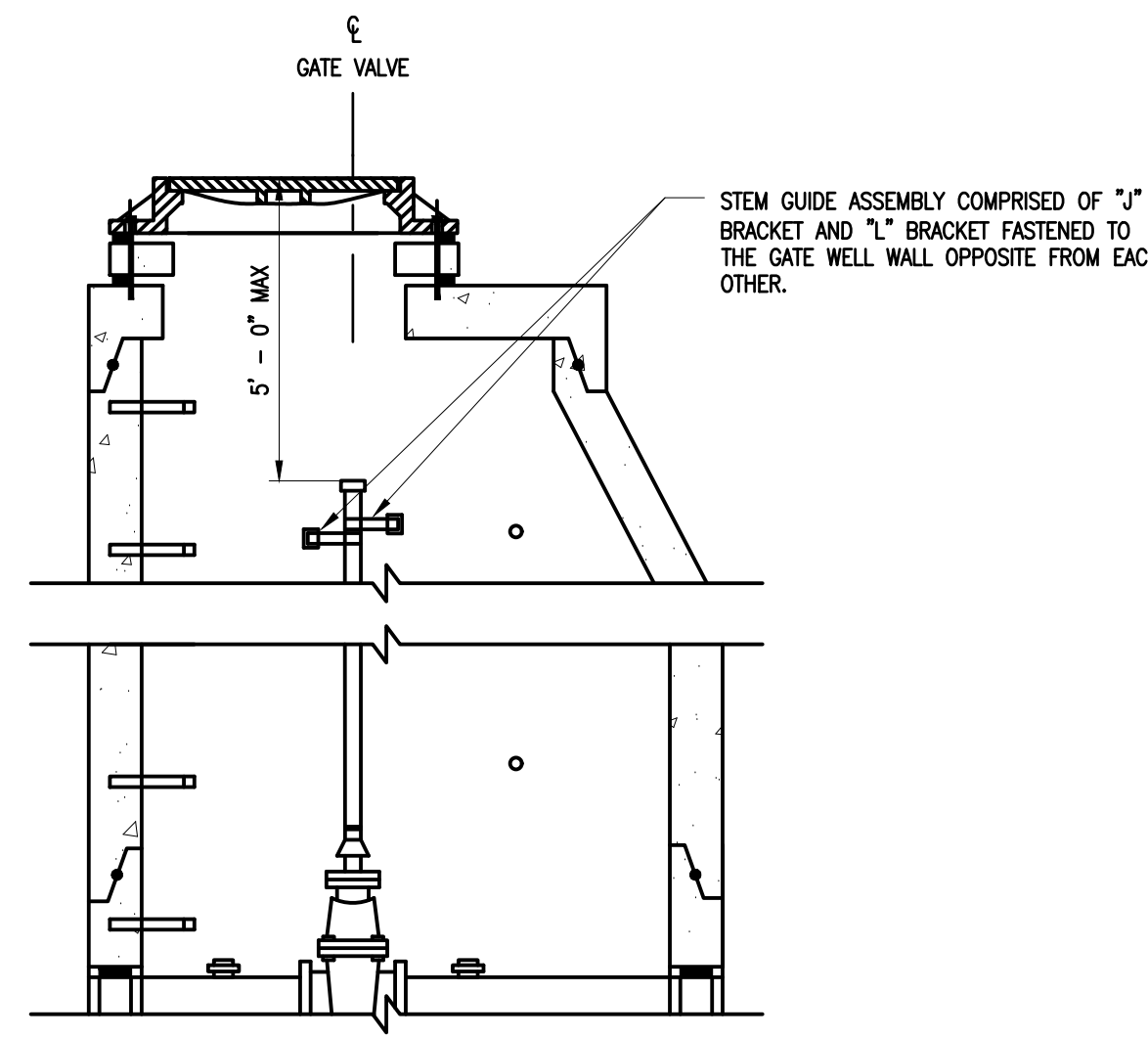

STEM EXTENSION DETAIL

NOTE: STEM EXTENSIONS SHALL BE PROVIDED AT ALL GATE VALVES WITH OPERATING NUTS AT A DISTANCE GREATER THAN 5" BELOW THE GROUND SURFACE.

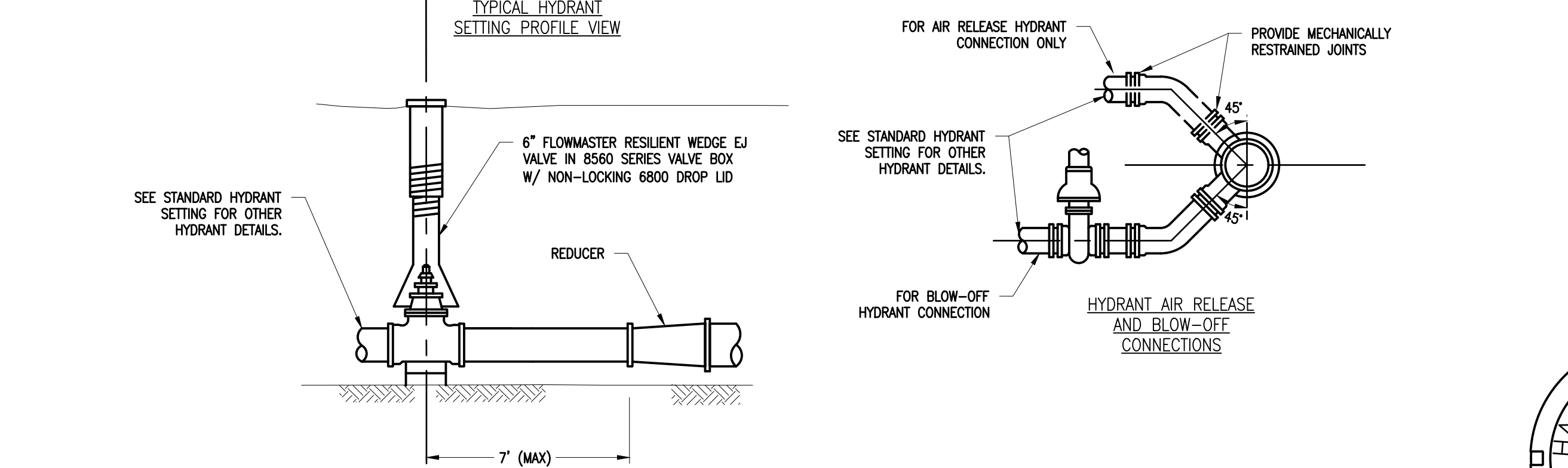
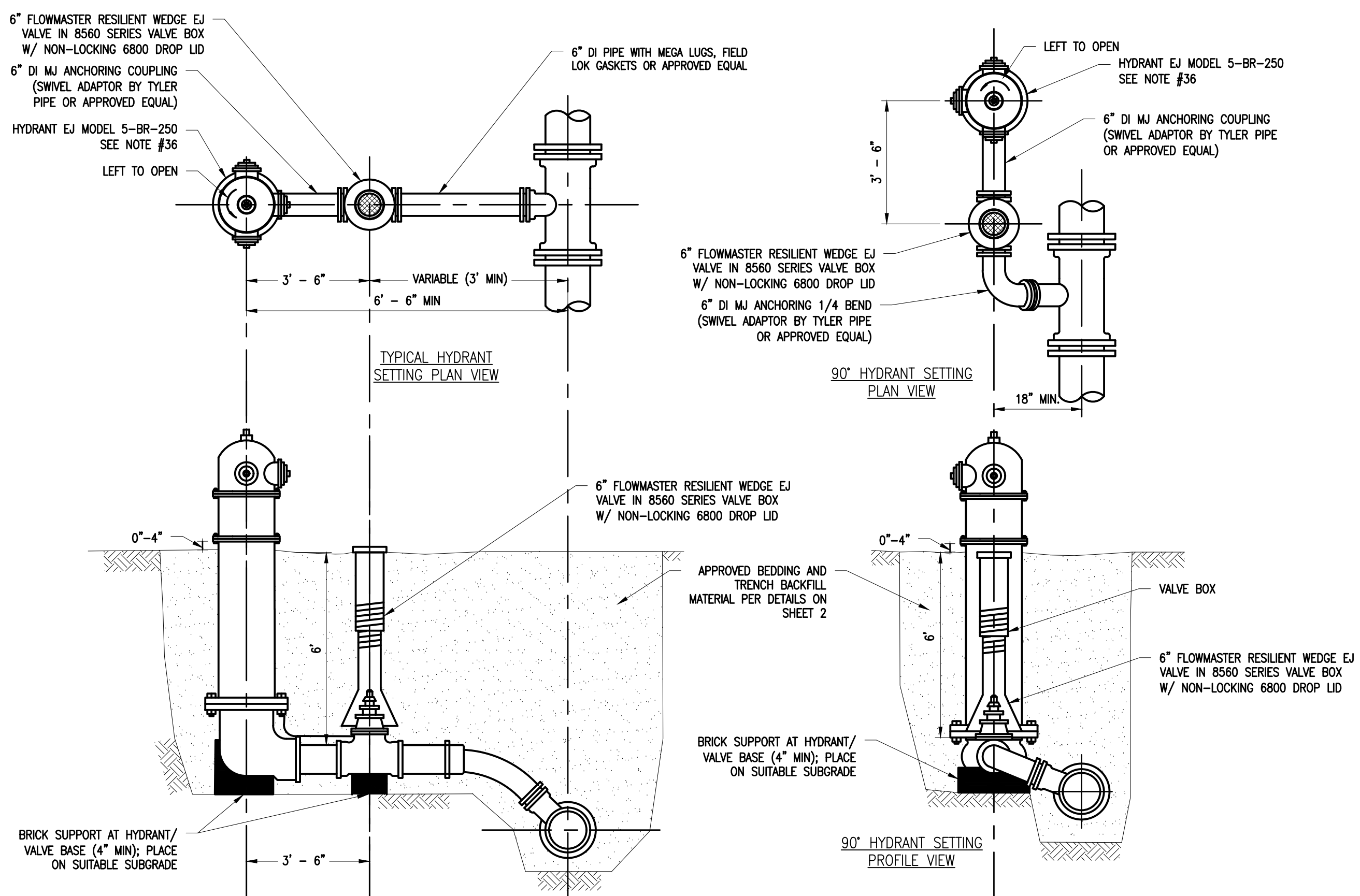

DETAIL OF HYDRANT SETTINGS

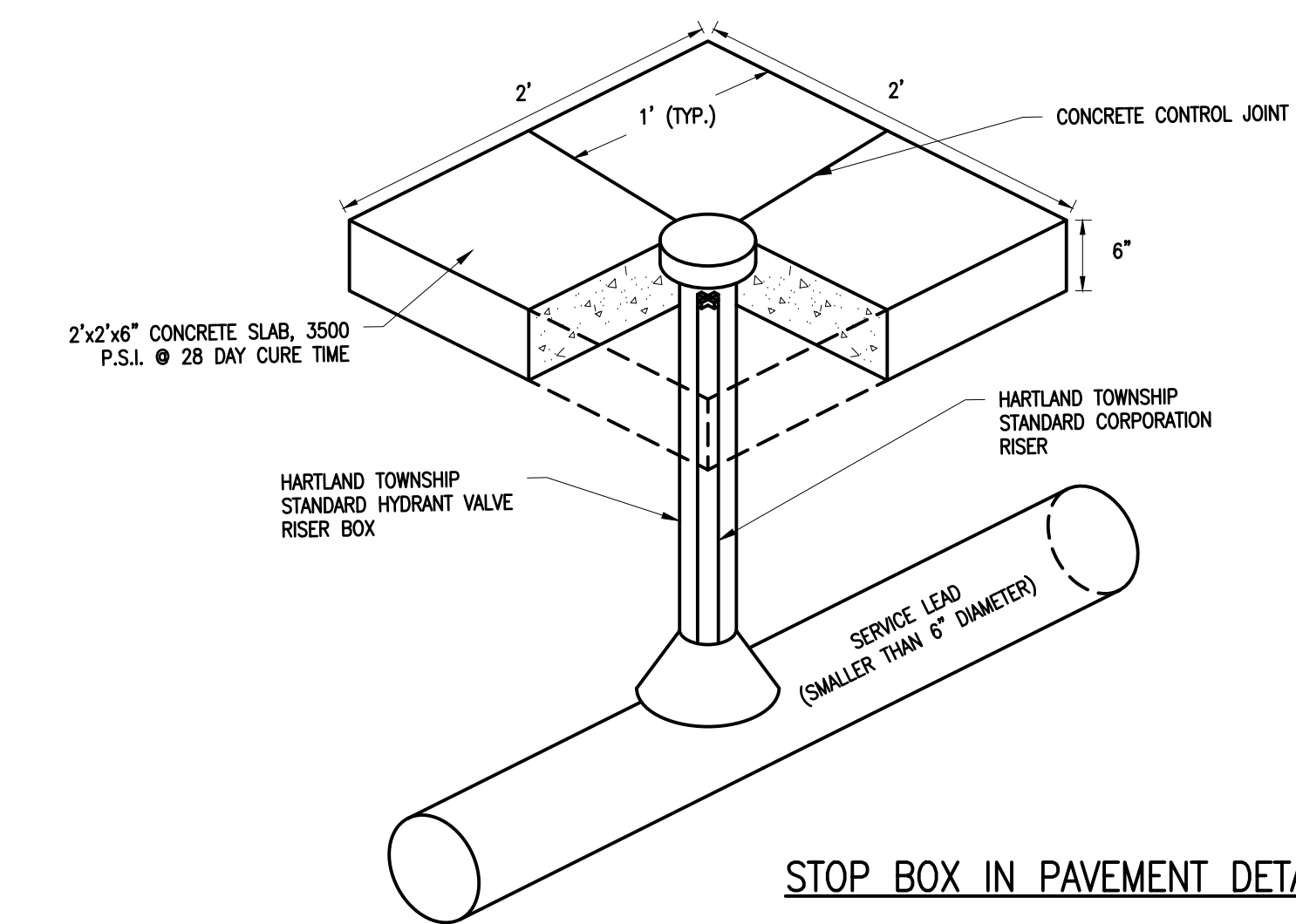

STOP BOX IN PAVEMENT DETAIL

NOTE: WHERE WATER SERVICE CORPORATION BOX FALLS WITHIN A PAVED AREA (PARKING LOT, SERVICE DRIVE AREA, ETC.) THE STOP BOX SHALL BE PLACED IN A STANDARD HYDRANT VALVE BOX. THE VALVE BOX SHALL BE CENTERED IN A 2'x2'x6" CONCRETE SLAB. CONCRETE CONTROL JOINTS SHALL BE PLACED IN SLAB AT 1' INTERVALS.

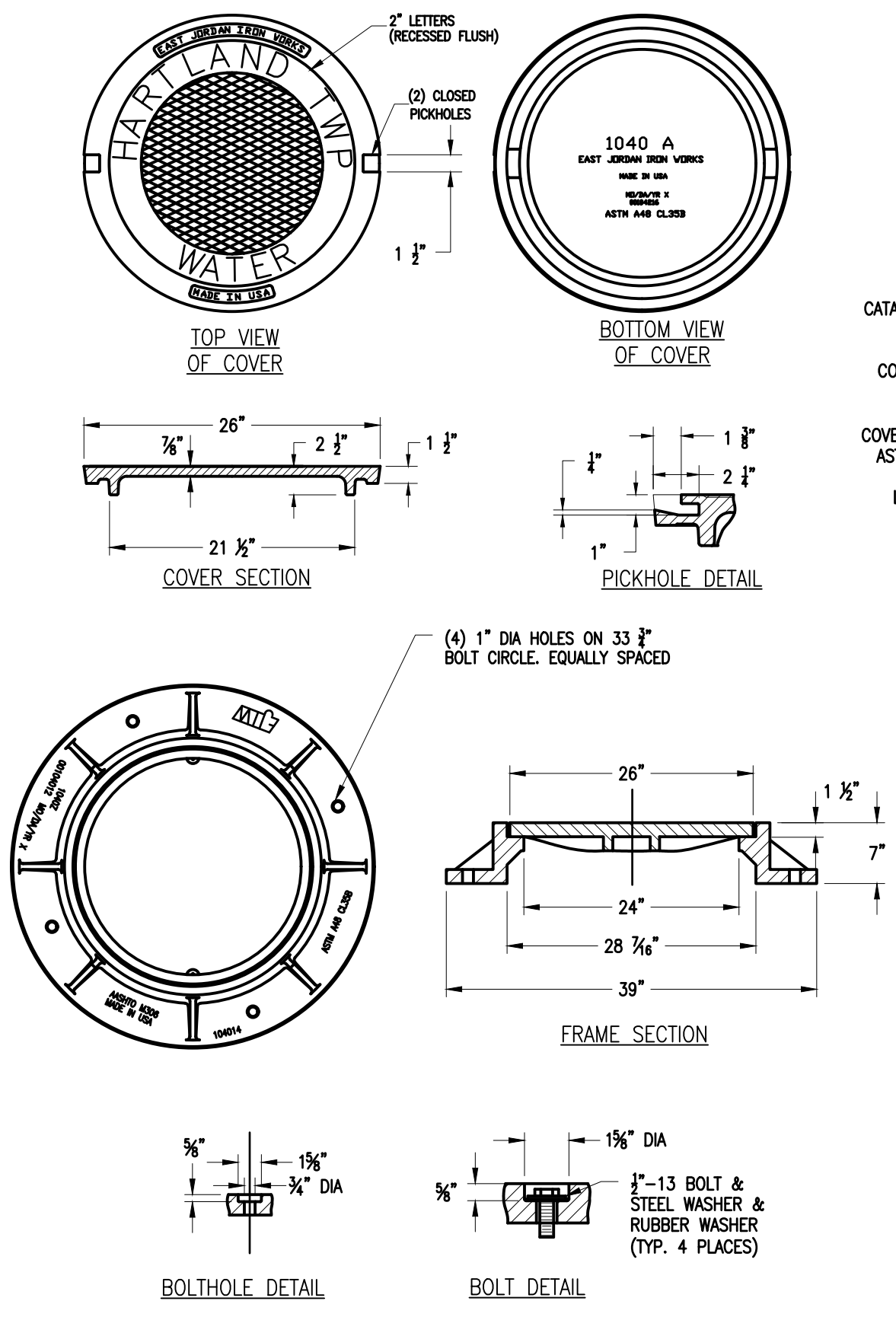

CAST IRON GATE WELL FRAME AND COVER

(SEE NOTE #32)

CATALOG NO. 1040A
EST. WT. 150 LBS
COVER - GRAY IRON
ASTM A48 CL35B
LOAD RATING HEAVY DUTY
COATING DIPPED

HARTLAND TOWNSHIP 2655 CLARK ROAD HARTLAND, MI 48351 P. (810) 832-7488 WWW.HARTLANDTWP.COM
DATE
REVISIONS
DATE
SCALE
H. N.T.S. V. N.T.S.
REVISIONS
DATE
COUNTY
LIVINGSTON COUNTY
DATE
RANGE
TOWNSHIP
DATE
REVISIONS

TABLE 23.6.5.A DUCTILE IRON WATER MAIN PIPE THRUST RESTRAINT LENGTH FOR HORIZONTAL BENDS															
		PIPE DIAMETER (inches)													
		3"	4"	6"	8"	10"	12"	14"	16"	18"	20"	24"	30"	36"	42"
BEND ANGLES (degrees)	11.25°	1	2	2	3	4	4	5	6	7	7	9	11	13	15
	22.5°	3	3	5	6	8	9	10	12	13	15	17	21	25	29
	30°	4	4	6	8	10	12	14	16	18	20	23	29	34	40
	45°	6	7	10	13	16	19	22	25	28	31	36	45	53	61
	60°	8	10	14	18	22	26	30	34	39	43	51	62	74	85
	90°	14	17	24	31	38	46	53	60	67	74	88	108	128	148
Unit Frictional Force (ft/lbs)		124	151	217	284	349	415	481	547	613	679	811	1,005	1,203	1,398
Unit Bearing Resistance (ft/lbs)		152	185	268	354	437	523	611	699	789	879	1,064	1,344	1,639	1,939

Assumptions: Cover = 6.0 feet
 Design Pressure = 150 psi
 Safety Factor = 1.5
 Laying Condition = Type 3
 Soil Designation = Clay 1
 Non-Polywrapped Pipe

☐ = Not Permitted (for 60°, use two 30° bends; for 90°, use two 45° bends)

* Data Table acquired from the Ductile Iron Pipe Research Association (DIPRA)

TABLE 23.6.5.B DUCTILE IRON WATER MAIN PIPE THRUST RESTRAINT LENGTH FOR VERTICAL UP BENDS															
		PIPE DIAMETER (inches)													
		3"	4"	6"	8"	10"	12"	14"	16"	18"	20"	24"	30"	36"	42"
BEND ANGLES (degrees)	11.25°	1	2	2	3	4	4	5	6	7	7	9	11	13	15
	22.5°	3	3	5	6	8	9	10	12	13	15	17	21	25	29
	30°	4	4	6	8	10	12	14	16	18	20	23	29	34	40
	45°	6	7	10	13	16	19	22	25	28	31	36	45	53	61
	60°	8	10	14	18	22	26	30	34	39	43	51	62	74	85
	90°	14	17	24	31	38	46	53	60	67	74	88	108	128	148
Unit Frictional Force (ft/lbs)		124	151	217	284	349	415	481	547	613	679	811	1,005	1,203	1,398
Unit Bearing Resistance (ft/lbs)		152	185	268	354	437	523	611	699	789	879	1,064	1,344	1,639	1,939

Assumptions: Cover = 6.0 feet
 Design Pressure = 150 psi
 Safety Factor = 1.5
 Laying Condition = Type 3
 Soil Designation = Clay 1
 Non-Polywrapped Pipe

☐ = Not Permitted (for 60°, use two 30° bends; for 90°, use two 45° bends)

* Data Table acquired from the Ductile Iron Pipe Research Association (DIPRA)

TABLE 23.6.5.C DUCTILE IRON WATER MAIN PIPE THRUST RESTRAINT LENGTH FOR VERTICAL DOWN BENDS															
		PIPE DIAMETER (inches)													
		3"	4"	6"	8"	10"	12"	14"	16"	18"	20"	24"	30"	36"	42"
BEND ANGLES (degrees)	11.25°	2	3	4	5	6	7	8	10	11	12	14	18	21	25
	22.5°	4	5	8	10	12	15	17	19	22	24	29	36	43	50
	30°	6	7	10	14	17	20	23	26	29	33	39	48	58	67
	45°	9	11	16	21	26	31	36	41	45	50	60	75	89	104
	60°	13	16	22	29	36	43	50	57	63	70	84	104	124	145
	90°	22	27	39	51	62	74	86	98	110	122	145	180	215	250
Unit Frictional Force (ft/lbs)		124	151	217	284	349	415	481	547	613	679	811	1,005	1,203	1,398
Unit Bearing Resistance (ft/lbs)		152	185	268	354	437	523	611	699	789	879	1,064	1,344	1,639	1,939

Assumptions: Cover = 6.0 feet
 Design Pressure = 150 psi
 Safety Factor = 1.5
 Laying Condition = Type 3
 Soil Designation = Clay 1
 Non-Polywrapped Pipe

☐ = Not Permitted (for 60°, use two 30° bends; for 90°, use two 45° bends)

* Data Table acquired from the Ductile Iron Pipe Research Association (DIPRA)

TABLE 23.6.5.D DUCTILE IRON WATER MAIN PIPE THRUST RESTRAINT LENGTH FOR TEES																
		PIPE DIAMETER OF MAIN PIPE RUN (inches)														
		3"	4"	6"	8"	10"	12"	14"	16"	18"	20"	24"	30"	36"	42"	
PIPE DIAMETER OF BRANCH RUN (inches)	3"	8	7	6	4	2	1	0	0	0	0	0	0	0	0	
	4"		10													
	6"			16	15	14	13	12	11	10	9	7	4	1	0	
	8"				22	22	21	20	19	19	18	16	14	11	8	
	10"					28	27	27	26	26	25	24	22	19	17	
	12"						34	33	33	32	31	29	27	25	23	
	14"							40	39	38	37	36	35	33	31	
	16"								46	45	45	44	43	41	40	
	18"									52	51	51	49	48	47	
	20"										58	57	56	55	54	
	24"											69	68	68	67	
	30"												87	86	85	
	36"													104	104	
	42"														122	
Unit Frictional Force (ft/lbs)		249	302	434	569	697	829	961	1,093	1,225	1,357	1,621	2,011	2,406	2,796	
Unit Bearing Resistance (ft/lbs)		152	185	268	354	437	523	611	699	789	879	1,064	1,344	1,639	1,939	

Assumptions: Cover = 6.0 feet
 Design Pressure = 150 psi
 Safety Factor = 1.5
 Laying Condition = Type 3
 Soil Designation = Clay 1
 Non-Polywrapped Pipe

☐ = Not Applicable

* Data Table acquired from the Ductile Iron Pipe Research Association (DIPRA)

TABLE 23.6.5.E DUCTILE IRON WATER MAIN PIPE THRUST RESTRAINT LENGTH FOR REDUCERS																
		DIAMETER OF LARGER PIPE (inches)														
		3"	4"	6"	8"	10"	12"	14"	16"	18"	20"	24"	30"	36"	42"	
DIAMETER OF SMALLER PIPE (inches)	3"		4	13	21	27	34	40	46	53	59	71	89	107	124	
	4"			10	18	25	32	39	45	52	58	70	88	106	124	
	6"				11	19	27	34	41	48	55	67	86	104	122	
	8"					11	20	29	37	45	50	64	83	102	120	
	10"						11	20	29	37	45	59	79	99	117	
	12"							11	21	30	38	54	75	95	114	
	14"								11	21	30	47	69	91	110	
	16"									11	21	40	63	85	106	
	18"										11	31	57	80	101	
	20"											22	49	73	96	
	24"												31	59	83	
	30"													33	60	
	36"														32	
	42"															
Unit Frictional Force (ft/lbs)			302	434	569	697	829	961	1,093	1,225	1,357	1,621	2,011	2,406	2,796	

Assumptions: Cover = 6.0 feet
 Design Pressure = 150 psi
 Safety Factor = 1.5
 Laying Condition = Type 3
 Soil Designation = Clay 1
 Non-Polywrapped Pipe

☐ = Not Applicable
 ☐ = Not Probable

* Data Table acquired from the Ductile Iron Pipe Research Association (DIPRA)

TABLE 23.6.5.F DUCTILE IRON WATER MAIN PIPE THRUST RESTRAINT LENGTH FOR DEAD ENDS															
Pipe Diameter (inches)	3"	4"	6"	8"	10"	12"	14"	16"	18"	20"	24"	30"	36"	42"	
Restraint Length (feet)	11	14	19	25	31	37	43	49	55	61	73	90	108	125	
Unit Frictional Force (ft/lbs)	249	302	434	569	697	829	961	1,093	1,225	1,357	1,621	2,011	2,406	2,796	

Assumptions: Cover = 6.0 feet
 Design Pressure = 150 psi
 Safety Factor = 1.5
 Laying Condition = Type 3
 Soil Designation = Clay 1
 Non-Polywrapped Pipe

* Data Table acquired from the Ductile Iron Pipe Research Association (DIPRA)



HARTLAND TOWNSHIP | 2655 CLARK ROAD | HARTLAND, MI 48851 | P. (810) 832-7488 | WWW.HARTLANDTWP.COM

HARTLAND TOWNSHIP
WATER MAIN
STANDARD DETAILS

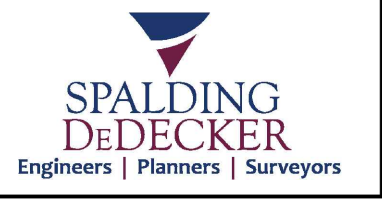

DRAWING PATH: J:\H\H\GEN\Standards\Standard Detail Sheets\2023 Updated\Details\CAD\Water Details\Hartland Twp.dwg Mar 30, 2023 - 9:55am

HIGH-DENSITY POLYETHYLENE (HDPE) WATER MAIN NOTES

In addition to the water main notes listed on sheet 3 of the standard details, the following notes will apply to construction projects using HDPE water main:

- MATERIALS**
- HDPE pipe, appurtenances, and installation methods shall conform to the most current edition of AWWA standard C906.
 - HDPE pipe shall be manufactured out of virgin material as defined in ASTM D3350. The pipe shall be made from high density PE 3408 polyethylene resin and the materials used must be listed and approved for use under NSF/ANSI Standard 14 and 61. HDPE pipe shall have a standard dimension ratio (SDR) of 11 or less, a hydrostatic design basis (HDB) of 1800 psi for water at 73.4°F and a minimum working pressure rating of 180 psi. No work except that obtained from the manufacturer's own production of the same formulation shall be used. The pipe shall be homogeneous throughout and shall be free of visible cracks, holes, foreign materials, blemishes, or other deleterious faults. A "Certificate of Compliance" shall be furnished for all materials supplied.
 - The physical appearance of the pipe having deformities such as concentrated ridges, discoloration, excessive spot roughness, pitting, varying wall thickness, etc., shall constitute sufficient basis for rejection. Pipe with gashes, nicks, abrasions or any physical damage that occurred during storage and/or handling which are wider or deeper than 10% of the wall thickness shall not be used and must be removed from the construction site. Any pipe that has been damaged or does not meet the Township's approval shall be replaced at the Contractor's expense.
 - Mechanical fittings used with HDPE pipe shall be specifically designed for or tested and found to be acceptable for use with HDPE by the fitting manufacturer. Mechanical fittings designed for other materials shall not be used.
 - Water service saddles on HDPE water main shall be "VA" Electrofusion Service Saddles by Fritec, Inc. or approved equal.
 - The mechanical joint fittings must conform to outside diameter requirements of ANSI/AWWA C111/A21 or ANSI/AWWA C153/A21.53 depending size. Butt fusion fittings shall meet AWWA C906 dimensional requirements.
 - Bolts, nuts, gaskets, and glands meeting ANSI/AWWA C111/A21.11 and ANSI/AWWA C153/A21.53 are required. Mechanical joint components shall be installed in accordance with manufacturer's recommendations.
 - Pipe and fittings must be marked as prescribed by AWWA C906 and NSF. Pipe markings shall include nominal size, OD base, dimension ratio, pressure class, working pressure rating, AWWA C906, material code designation PE 3408, manufacturer's name, manufacturer's production code including day, month, year extruded, and manufacturer's plant and extrusion line; and NSF logo. Permanent identification of piping shall be provided by co-extruding longitudinal blue stripes into the outside surface of the pipe (stripes printed or painted shall not be acceptable) or the pipe material shall be black with a blue shell.
- INSTALLATION**
- Directional Drilled Water Main and Bore & Jack Water Main must be provided with two tracer wires. Wire shall be copper, 8-gauge stranded, blue insulated per Township's requirements, or Copperhead Industries #8 AWG Blue Coated solid shot extra strength tracer wire.
 - Personnel trained in the use of butt-fusion equipment shall perform the joining of polyethylene pipe by methods recommended for new pipe connections. Personnel directly involved with installing the new pipe shall have received training in the proper methods for handling and installing the HDPE pipe by a qualified representative and certification of this training shall be provided to the Township.
 - Connections to HDPE pipe shall not be made immediately after the pipe has been installed. The fused pipe should be laid in the trench and be allowed to reach an equilibrium temperature overnight (24-hour period) in its surrounding environment.
 - The HDPE pipe must be properly aligned at all transitions to conventional or HDPE water main and appurtenances.
- TESTING**
- The polyethylene pipe shall be pressure tested after the line and all fittings and valves have been installed. Connections may be left exposed for visual leak inspection. Under no circumstances shall HDPE pipe be pressure tested when the temperature of the pipe is above 80°F.
 - Connection to an existing water main shall be made only after pressure and bacteriological test have been successfully completed. The Township consultant must be present for the test and review the results. Testing and disinfection procedures shall meet the requirements of ANSI/AWWA-C500/C651. The water main shall pass a test of 150 psi for a two (2) hour period. Water loss shall not exceed a rate of 11.65 U.S. gallons per inch diameter per mile of water main in twenty-four (24) hours. Bacteria sample (24) hours back to back.
- PIPE BURSTING PROJECTS**
- The method approved for rehabilitation of existing water mains by pipe bursting and installation of new HDPE pipe is T.T. Technologies GRINDROCK SYSTEMS, (800-533-2078) or approved equal. All contractors must be licensed to use the particular technology proposed for this work.
 - The pipe-bursting tool shall be designed and manufactured to force its way through existing pipe materials by fragmenting the pipe and compressing the old pipe sections into the surrounding soil as it progresses. The bursting tool shall be pneumatic and shall generate enough force to burst and compact the existing pipeline.
 - The Manufacturer's specifications shall dictate what size tool should be used in what diameter pipe, as well as parameters of what size tool for percentage of upset allowed.
 - Prior to construction, the Contractor shall develop and provide to Hartland Township for review and approval a temporary water system plan to supply water services to area residents and businesses during pipe bursting operations. It is anticipated that the temporary system will be fed from existing fire hydrants. The temporary system and hydrants shall have passed bacteriological testing prior to use.
 - All service connections on the existing water main that is to be burst, or will be taken out of service, shall be connected to the temporary water system prior to mainline bursting, disinfection, testing and service reconnection operations. Temporary service connections shall be made at the water service stop box by disconnecting the existing water service and connecting the temporary water line to the stop box.

EQUIVALENT DUCTILE IRON PIPE SIZES (DIPS)		
NOMINAL PIPE SIZE (DIPS)	O.D. SIZE (INCHES)	MIN WALL THICKNESS SDR 11 (180 PSI) (INCHES)
6"	6.90	0.627
8"	9.05	0.823
12"	13.20	1.200
16"	17.40	1.582
20"	21.60	1.964
24"	25.80	2.345

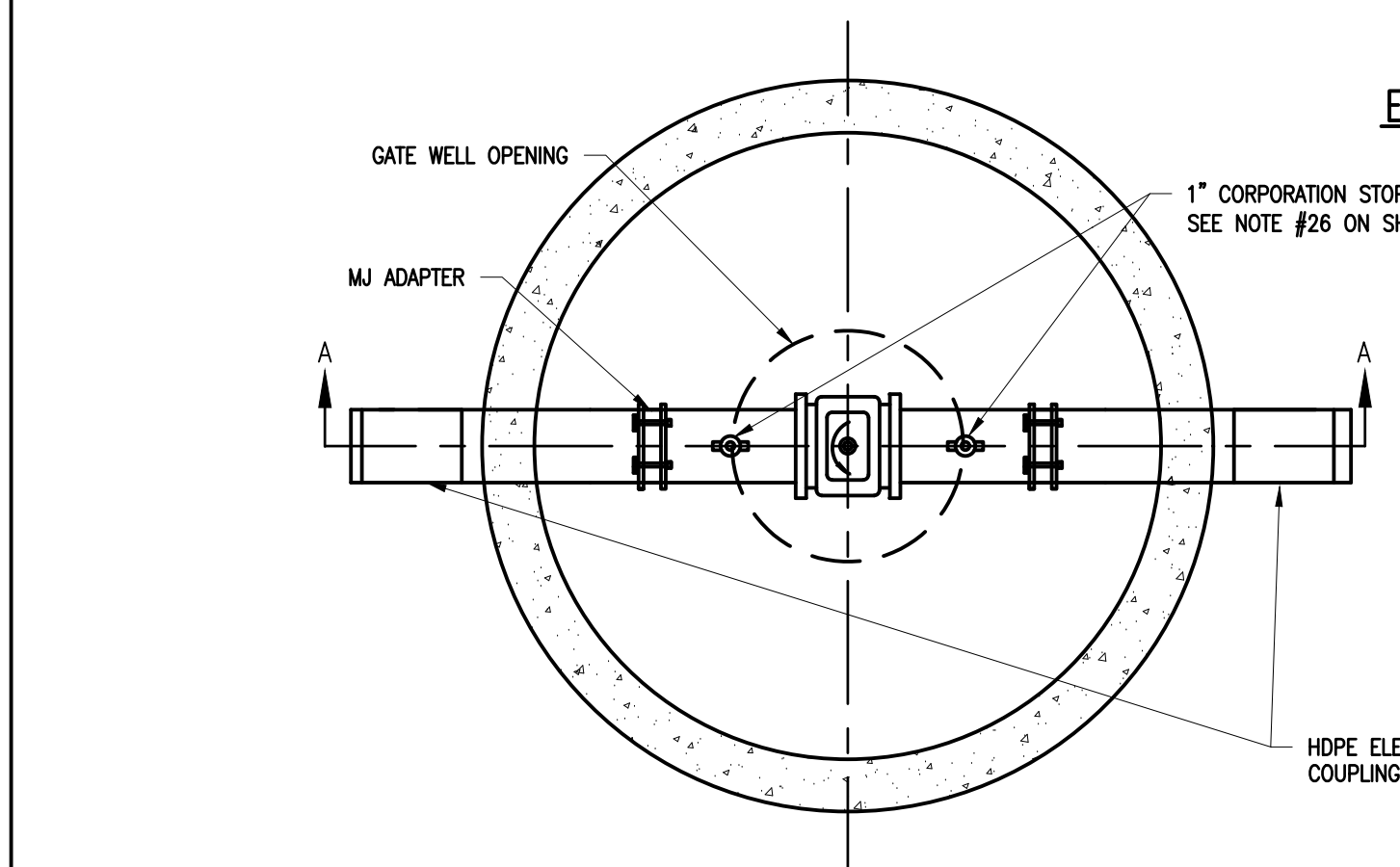
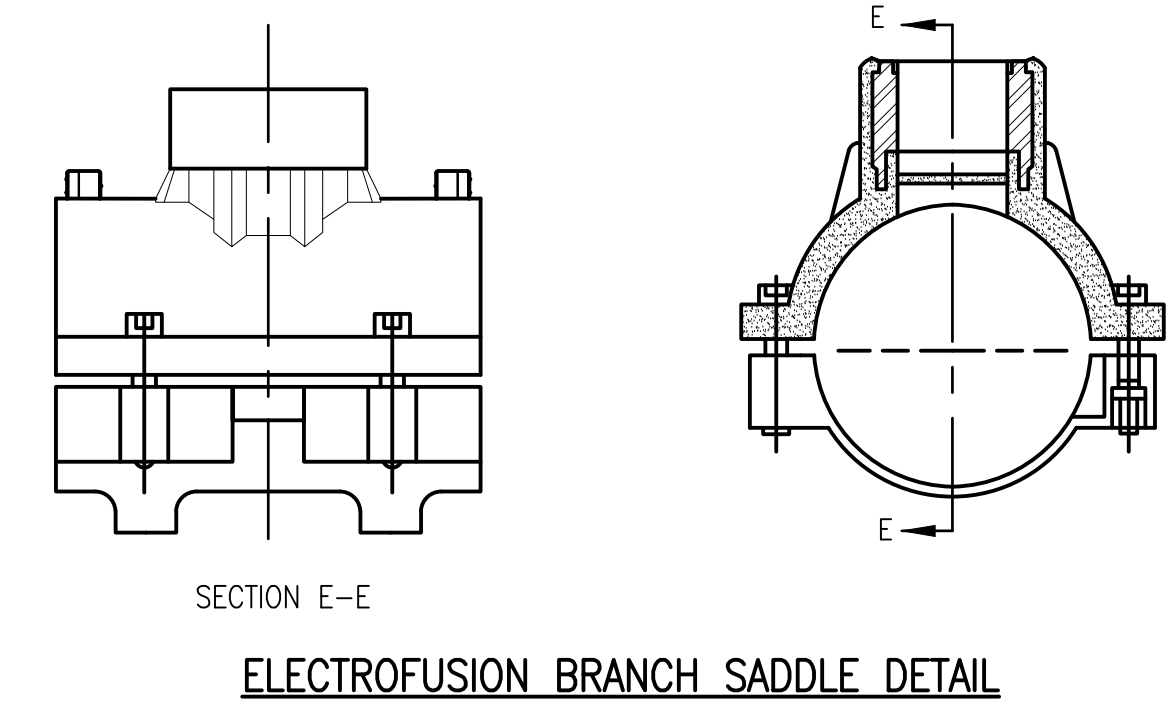
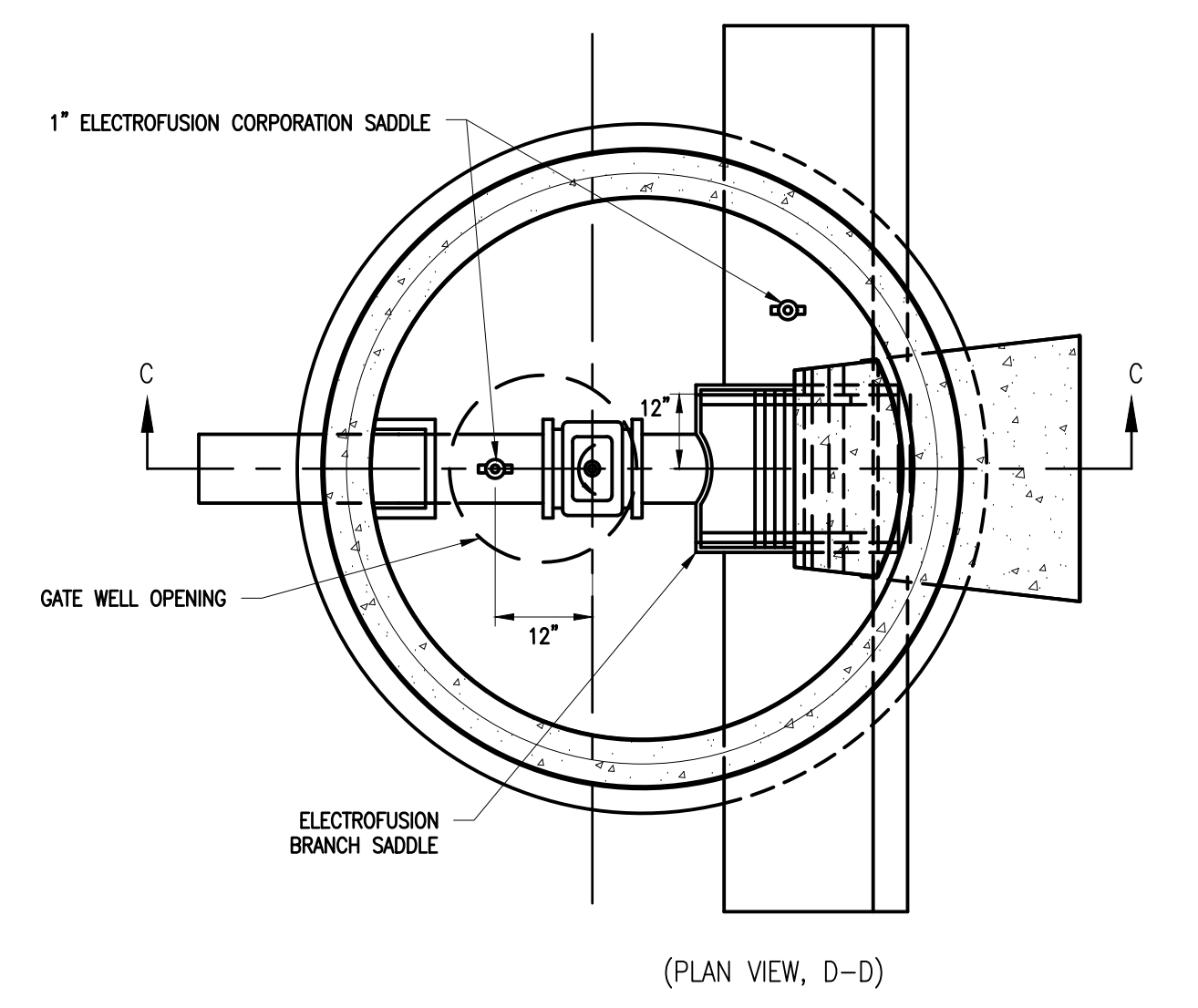
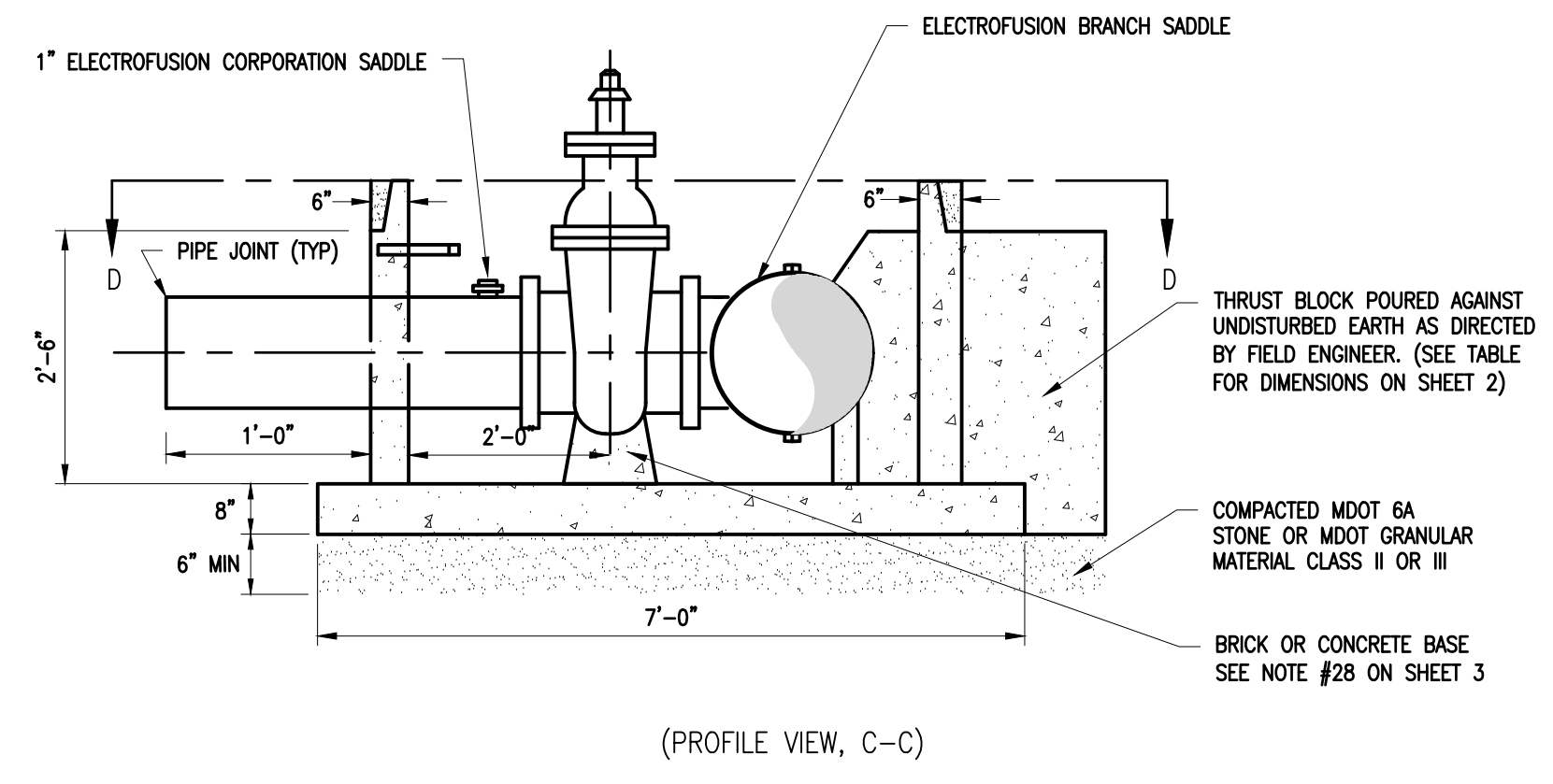
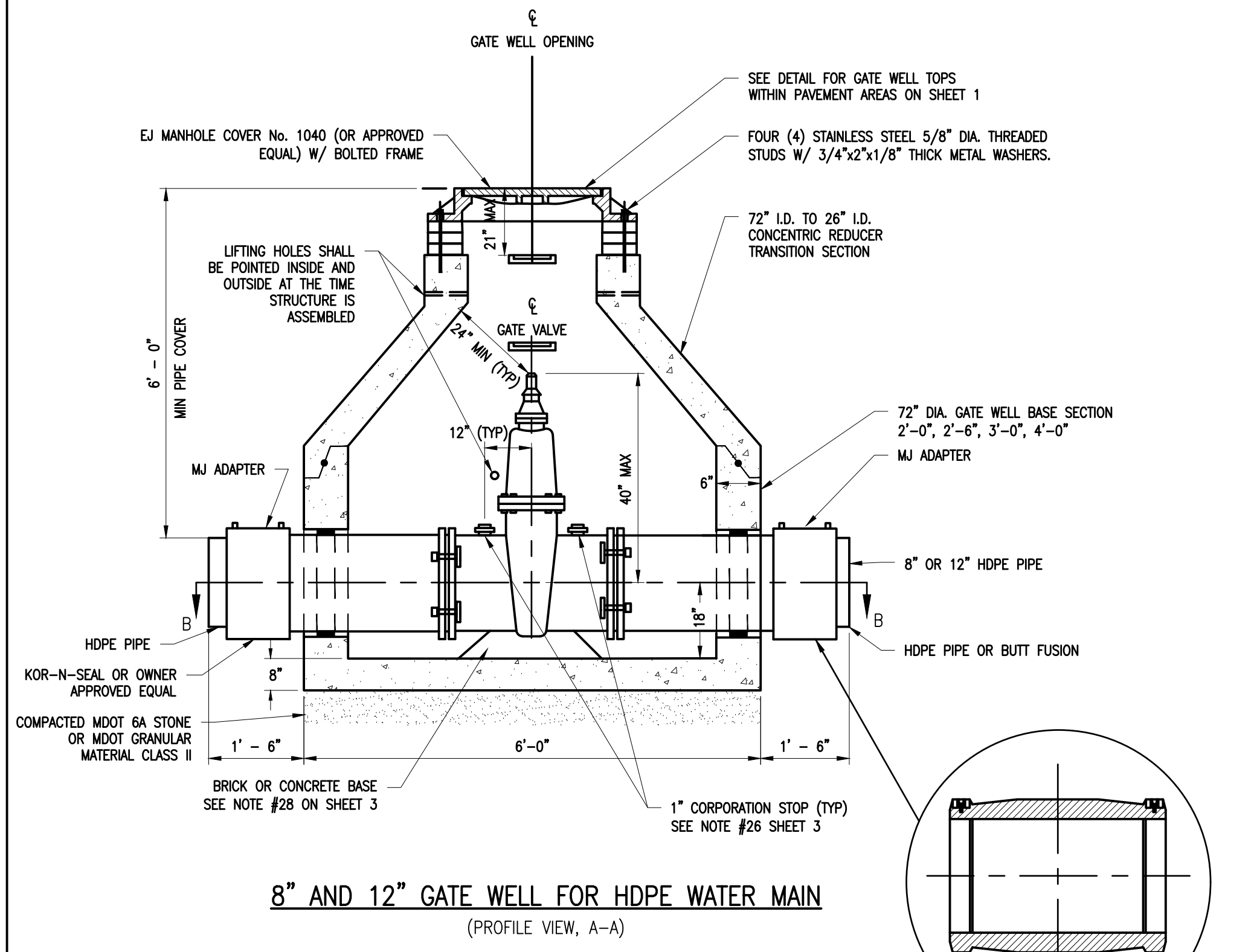

ELECTROFUSION DIPS COUPLINGS

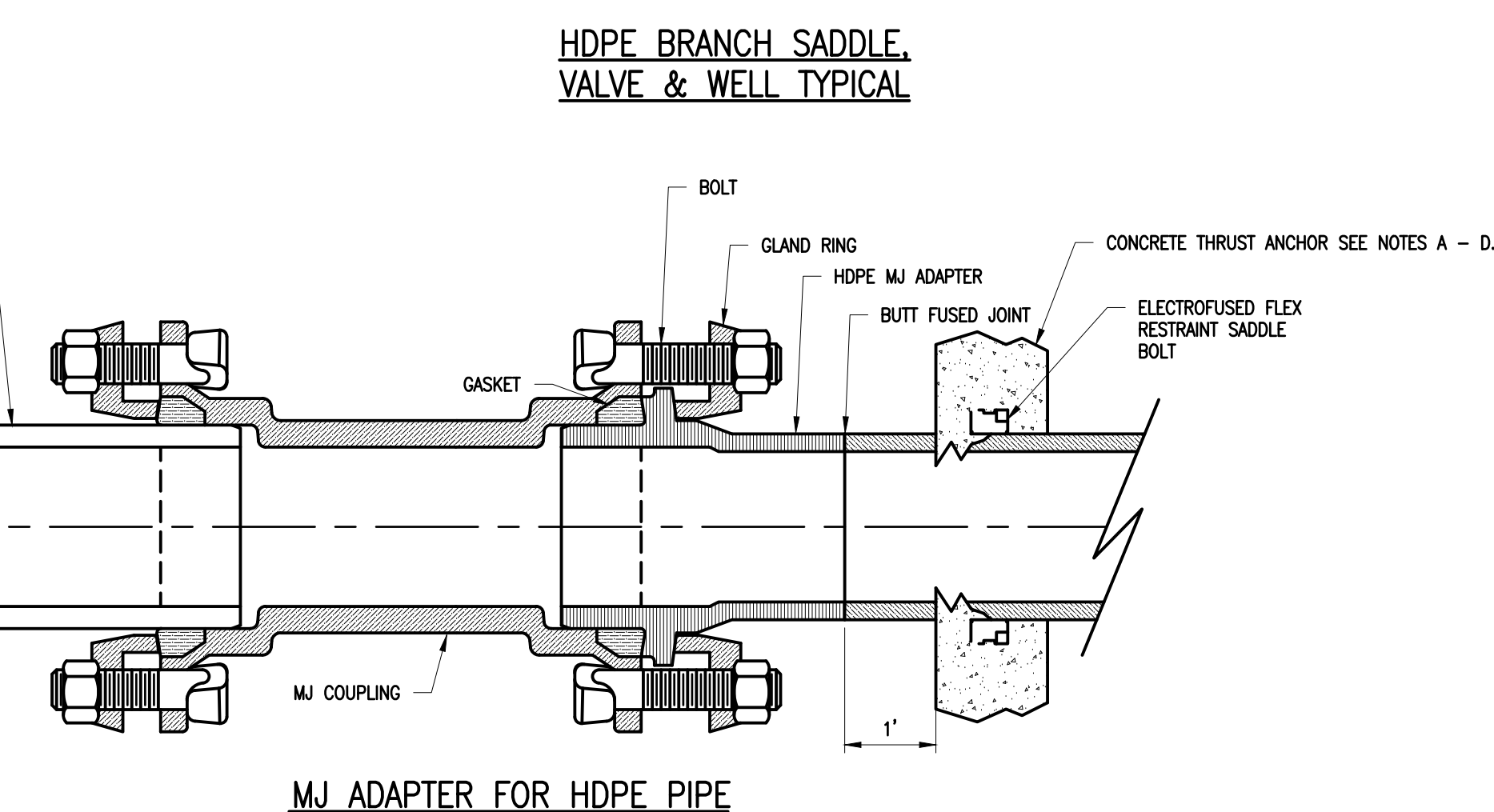

8" AND 12" GATE WELL TYPICAL FOR HDPE WATER MAIN (PLAN VIEW, B-B)

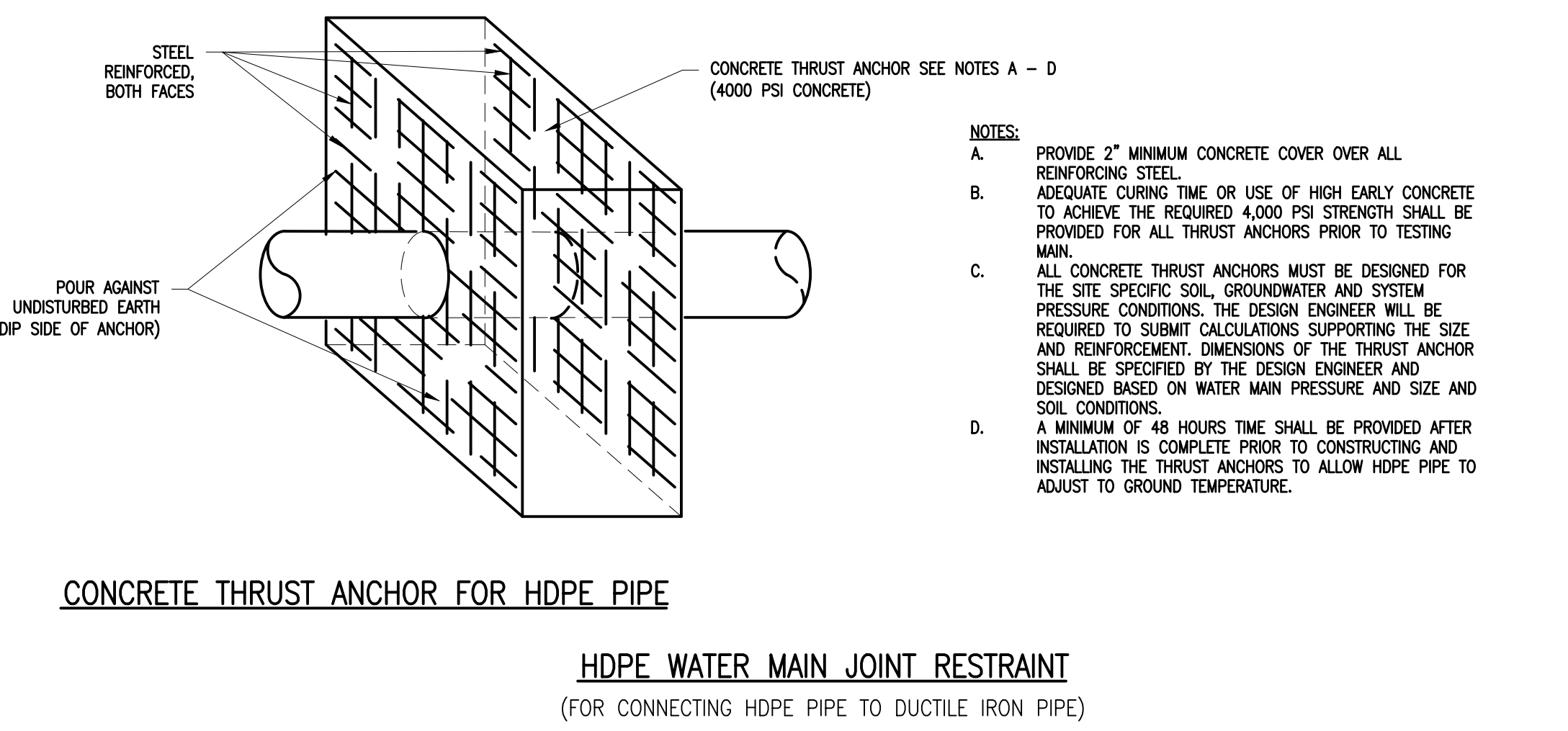

- NOTES:**
- PROVIDE 2" MINIMUM CONCRETE COVER OVER ALL REINFORCING STEEL.
 - ADEQUATE CURING TIME OR USE OF HIGH EARLY CONCRETE TO ACHIEVE THE REQUIRED 4,000 PSI STRENGTH SHALL BE PROVIDED FOR ALL THRUST ANCHORS PRIOR TO TESTING MAIN.
 - ALL CONCRETE THRUST ANCHORS MUST BE DESIGNED FOR THE SITE SPECIFIC SOIL, GROUNDWATER AND SYSTEM PRESSURE CONDITIONS. THE DESIGN ENGINEER WILL BE REQUIRED TO SUBMIT CALCULATIONS SUPPORTING THE SIZE AND REINFORCEMENT. DIMENSIONS OF THE THRUST ANCHOR SHALL BE SPECIFIED BY THE DESIGN ENGINEER AND DESIGNED BASED ON WATER MAIN PRESSURE AND SIZE AND SOIL CONDITIONS.
 - A MINIMUM OF 48 HOURS TIME SHALL BE PROVIDED AFTER INSTALLATION IS COMPLETE PRIOR TO CONSTRUCTING AND INSTALLING THE THRUST ANCHORS TO ALLOW HDPE PIPE TO ADJUST TO GROUND TEMPERATURE.

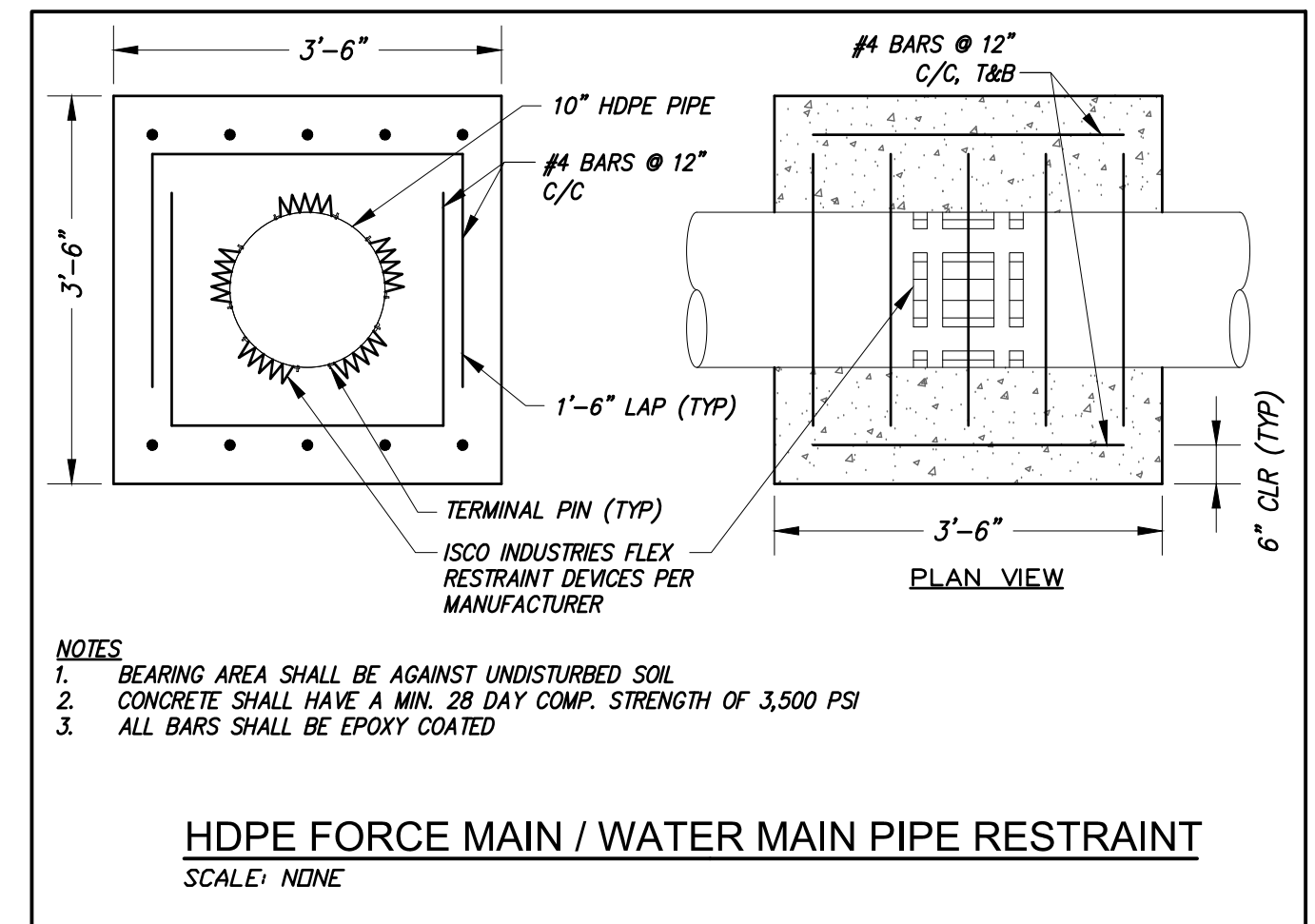

- NOTES:**
- BEARING AREA SHALL BE AGAINST UNDISTURBED SOIL.
 - CONCRETE SHALL HAVE A MIN. 28 DAY COMP. STRENGTH OF 3,500 PSI.
 - ALL BARS SHALL BE EPOXY COATED.

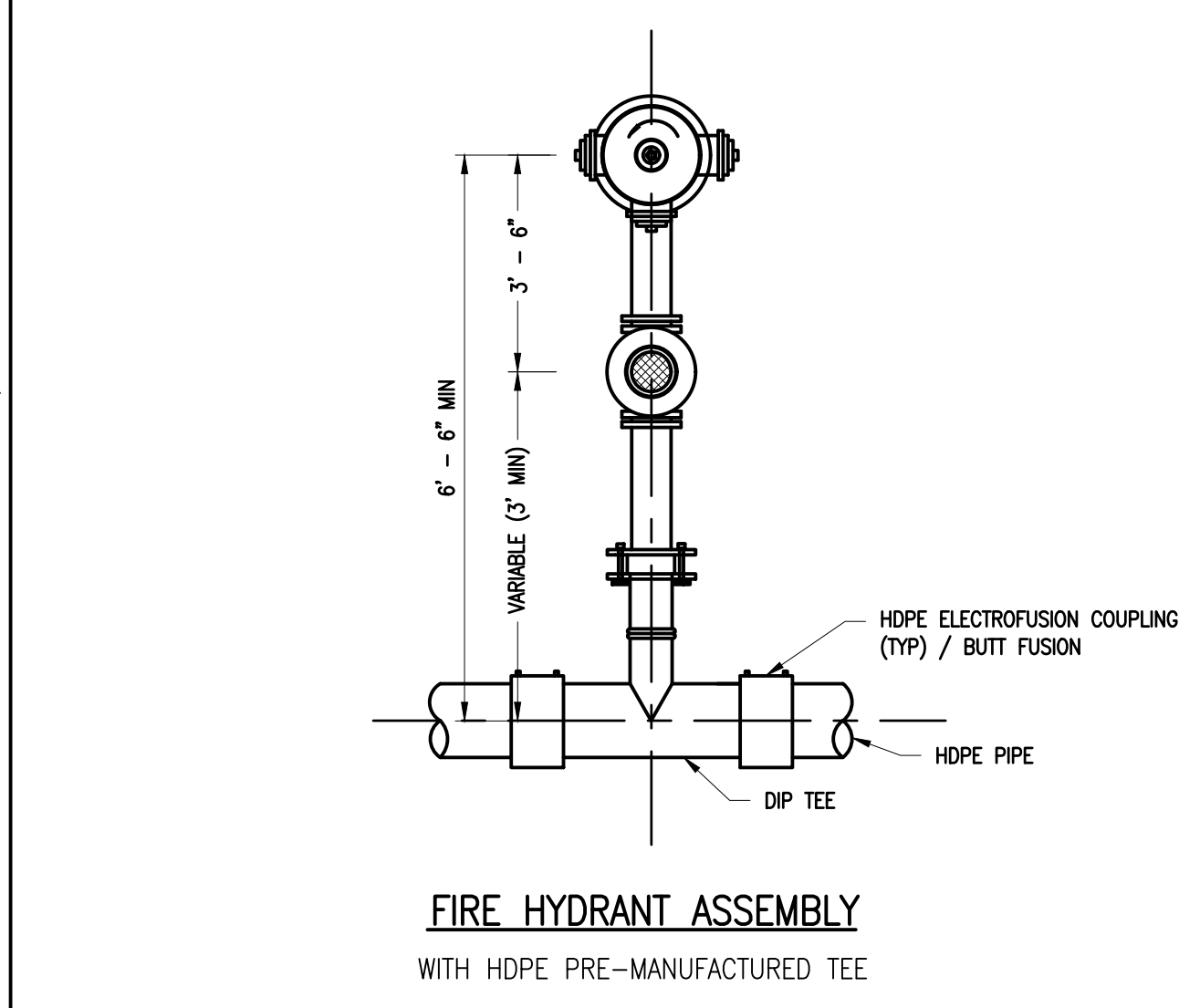

FIRE HYDRANT ASSEMBLY WITH HDPE PRE-MANUFACTURED TEE